

Gold Coast and Queensland- New South Wales border area

First-strike Oil Spill Response Plan

A supplement to the Queensland Coastal Contingency Action Plan

Document control sheet

Prepared by Maritime Services Branch
Division Maritime Safety Queensland
Location Floor 6, Transport House, 230 Brunswick Street, Brisbane 4006
Version no. 4.1
Revision date February 2014
Status Final
File Number 225/00028

Document sign-off

Version 1 of this document was approved by the Chair of the Queensland National Plan State Committee in July 2006. Subsequent amendments have been of an administrative nature only and have not changed the intent of the document.

Contact for enquiries and proposed changes

If you have any questions or suggested improvements please phone the Manager, Pollution Response on 07 3066 3911 or email pollution@msq.qld.gov.au

1	INTRODUCTION	4
2	SCOPE.....	4
3	OBJECTIVE	4
4	ROLES AND RESPONSIBILITIES.....	4
5	STATEMENT OF INTENT	5
6	THREAT ASSESSMENT	5
7	POSSIBLE SPILL SCENARIOS	6
8	RESPONSE OPTIONS	6
9	INCIDENT CONTROL CENTRE.....	6
10	RESPONSE AND HANDOVER ARRANGEMENTS.....	6
11	FIRST-STRIKE EQUIPMENT	7
12	RESPONSE TEAM STRUCTURE	7
13	CONTACT LIST FOR GOLD COAST AREA.....	8
14	CONTACT LIST FOR QUEENSLAND/NEW SOUTH WALES BORDER AREA	8
	APPENDIX A – MAP OF GOLD COAST REGION	9
	APPENDIX B – MAP OF QUEENSLAND/NEW SOUTH WALES BORDER REGION.....	9
	APPENDIX B – MAP OF QUEENSLAND/NEW SOUTH WALES BORDER REGION.....	11

1 Introduction

This plan has been prepared by the Department of Transport and Main Roads in accordance with the agreed arrangements of Australia's National Plan for Maritime Environmental Emergencies (National Plan) and the requirements of the Transport Operations (Marine Pollution) Act 1995. It is a supplement to the Queensland Coastal Contingency Action Plan.

2 Scope

This plan deals with first-strike response to oil spills from ships within the Gold Coast area (see Appendix A for a map of the area). It also extends to spills that threaten or impact on the Queensland/New South Wales border region (see Appendix B for map of the border region).

3 Objective

The aim of this plan is promote the cooperative spirit of the National Plan to describe the operational arrangements for response to oil spills within Gold Coast and Queensland/New South Wales border area. It also describes the agreed first-strike response arrangements, identifies available resources and provides key contact information.

This plan is not a stand alone document and should be read in conjunction with:

- The National Plan for Maritime Environmental Emergencies (National Plan)
- Queensland Coastal Contingency Action Plan (QCCAP)
- Maritime Safety Queensland's Standard Operating Procedures for oil spill response.
- The Oil Pollution First-Strike Response Deed between Gold Coast Waterways Authority and the State of Queensland, acting through Maritime Safety Queensland.

4 Roles and Responsibilities

Key roles and responsibilities within the scope of this plan are defined as:

- The Queensland Government acting through TMR is both statutory and combat Agency for ship-sourced oil spills that impact or are likely to impact Queensland coastal waters.
- The New South Wales government, acting through the New South Wales Maritime Authority, is both statutory and combat agency for oil spills within New South Wales coastal waters.
- The Queensland Department of Environment and Heritage Protection (DEHP) is the statutory agency for all land-sourced oil spills and is responsible for providing environmental and scientific advice to the Incident Controller during response to all ship sourced spills.
- TMR will assist DEHP by responding to land-sourced oil spills that impact or are likely to impact Queensland coastal Waters.
- The Gold Coast City Council is authorised to clean oil from impacted shorelines within its jurisdiction.

Details of the roles and responsibilities may be found in Schedule 1 to the Inter-Governmental Agreement (IGA) on Australia's National Plan for Maritime Environmental Emergencies.

5 Statement of Intent

In accordance with the cooperative spirit of the National Plan and the National Plan IGA:

- Maritime Safety Queensland agrees, where possible, to assist the New South Wales Maritime Authority combat ship sourced oil spills that impact or threaten the Queensland/New South Wales border region
- Gold Coast City Council agrees, where possible, to assist Maritime Safety Queensland respond to oil spills, in particular oiled shorelines, within its jurisdiction.

6 Threat Assessment

The Gold Coast region has a high concentration of recreational boating activity along with a medium-sized fishing industry and local tourism operations. The major hubs of these activities are centred at the Southport Broadwater and connecting canals and river systems. The areas include large yacht marinas, many private pontoons and jetties as well as ship repair, maintenance, refuelling facilities and commercial fishing wharves.

While the risk of a large oil spill is very low, the area has a history of frequent small spills (less than 20 litres) of diesel, fuel or bilge oil. These spills invariably come from commercial and recreational vessels moored or operating within the Broadwater, marinas, and private pontoons.

Depending upon its origin and prevailing weather and tidal conditions, an oil spill will generally move up and downstream with the tides. Most spills are likely to quickly evaporate or disperse without causing significant environmental damage but vapours from spilt diesel or fuel could adversely affect residents, people using marina or tourist facilities within the area. Spills also have the capacity to adversely affect local tourism and small business operators.

Activities that regularly occur within the scope of this plan and present a credible threat include:

- refuelling operations
- fishing vessels entering and leaving the Broadwater
- small vessels experiencing difficulties on the Jumpinpin Bar or Gold Coast Seaway
- bilge or fuel discharges from small commercial, fishing and recreational vessels
- slipway operations
- land sourced spills entering the system via stormwater drains
- submerged vessels at pontoons or private jetties leaking fuel
- spills of crude oil, heavy fuel oil or waste oil from larger trading ships operating offshore are also possible but less likely
- other natural phenomenon that are sometimes reported as oil spills, including:
 - coral spawn and trichodesium
 - rotting seaweed or similar marine vegetation – generally on beaches
 - large schools of fish
 - current or tidal eddies forming a 'smooth sheen' on the water
 - stained brackish water seepage from dunes or rock ledges due to coffee rock or tea trees will need to be assessed but will not require any cleanup action.

7 Possible Spill Scenarios

The types of incidents most likely to occur within the region are small spills of petrol, diesel fuel or bilge oil from commercial, fishing and recreational ships operating or anchored in the waterways. However spills of up to 20,000 litres of diesel fuel or petrol from damaged or submerged vessels, ruptured pipelines are road tanker accidents are also possible. There is also a slight chance of pollution from downed aircraft.

8 Response Options

The following guidelines apply to first-strike response within the region.

Area	Monitor	Contain & recover	Protect resources	Shoreline cleanup	Apply dispersant
Offshore waters	Yes	No	If viable	Yes	Yes *
Seaway entrance and Jumpinpin Bar	Yes	If viable	Yes	Yes	No *
Tallebudgera Creek and Currumbin Creek	Yes	If viable	Yes	Yes	No *
Southern Moreton Bay and Broadwater	Yes	If viable	Yes	Yes	No *
Nerang River and Coomera River	Yes	Yes	Yes	Yes	No *
Coastal shoreline	Yes	Yes	Yes	Yes	No *
Marinas	Yes	Yes	Yes	Yes	No *

* Refer to the Queensland Coastal Contingency Action Plan for information on the use of oil spill dispersants and chemical countermeasures for oil and chemical spill response.

9 Incident Control Centre

Depending upon the severity of an incident the Incident Controller may establish an Incident Control Centre and/or Advanced Operations Centre at:

- Maritime Safety Queensland regional office, Southport.
- Maritime Safety Queensland regional office, Pinkenba

10 Response and Handover Arrangements

Early first-strike response action should include an assessment of the time and resources required to effectively manage each incident. Where a response is likely to be prolonged or exceed the region's first-strike response capacity, assistance should be requested from other Maritime Safety Queensland regions. When determining the need for assistance the Gold Coast region should consider the number and availability of local trained response personnel, their ability work safely without the need for excessive work hours and the capacity of the region's first-strike response equipment. Requests for assistance should be made as soon as possible and preferably in the first situation report (SITREP).

11 First-strike equipment

Oil spill response equipment is located at the Maritime Safety Queensland regional office, Seaworld Drive, Southport.

Equipment type	Quantity
General purpose boom (MG 500 boom)	200 m
Weir skimmer kit (Foilex micro skimmer)	1
Oil transfer pump (38 mm air driven pump)	1
Recovered oil container (fast tank 10 000 litres)	1
Anchor kit	1
Sorbent boom	240 m
Sorbent pads	1000

12 Response team structure

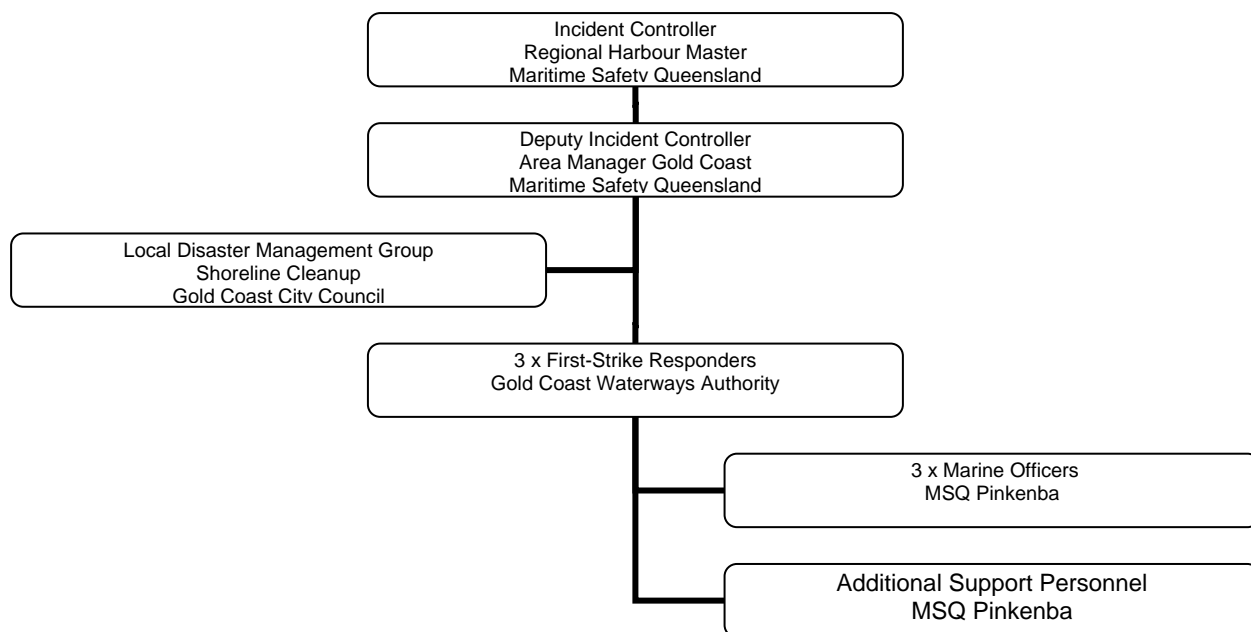

13 Contact list for Gold Coast area

Role	Position	Office phone	Mobile/after hours
Spill report	Duty Officer Gold Coast Waterways Authority		5539 7373 24 hrs
Alternate spill report	Gold Coast Seaway Tower	5591 2948 5 AM to 8 PM only	
Alternate spill report	Brisbane Port Control	3305 1700 24 hr	
Incident Controller	Regional Harbour Master (Brisbane) MSQ	3632 7500	0419 600 261
Deputy Incident Controller	Area Manager (Gold Coast) MSQ	5585 1814	0419 729 592
Gold Coast Waterways Authority	Marine Officers (First Strike Responders)	5539 7363	0407 752 884
Finance and administration (First Strike)	Administration Manager, Gold Coast Waterways Authority	5539 7366	0434 606 137
Finance and administration (MSQ)	Manager (Corporate Support) Brisbane	3632 7508	0437 549 410
Environment and scientific support	Duty Officer DEHP	1300 130 372 24 hr	
Foreshore cleanup	Gold Coast City Council	1800 637000	

14 Contact list for Queensland/New South Wales border area

Role	Position	Office phone	Mobile/after hours
NSW Maritime Authority	Area Officer	5536 1001	0418 654 739
NSW Maritime Authority	24 hour Duty Officer pager		02 9962 9074
NSW Maritime Authority	Manager, Marine Environment & Protection, Shipping, Security & Environment	02 9563 8749	0419 484 446

Appendix A – Maps of Gold Coast region

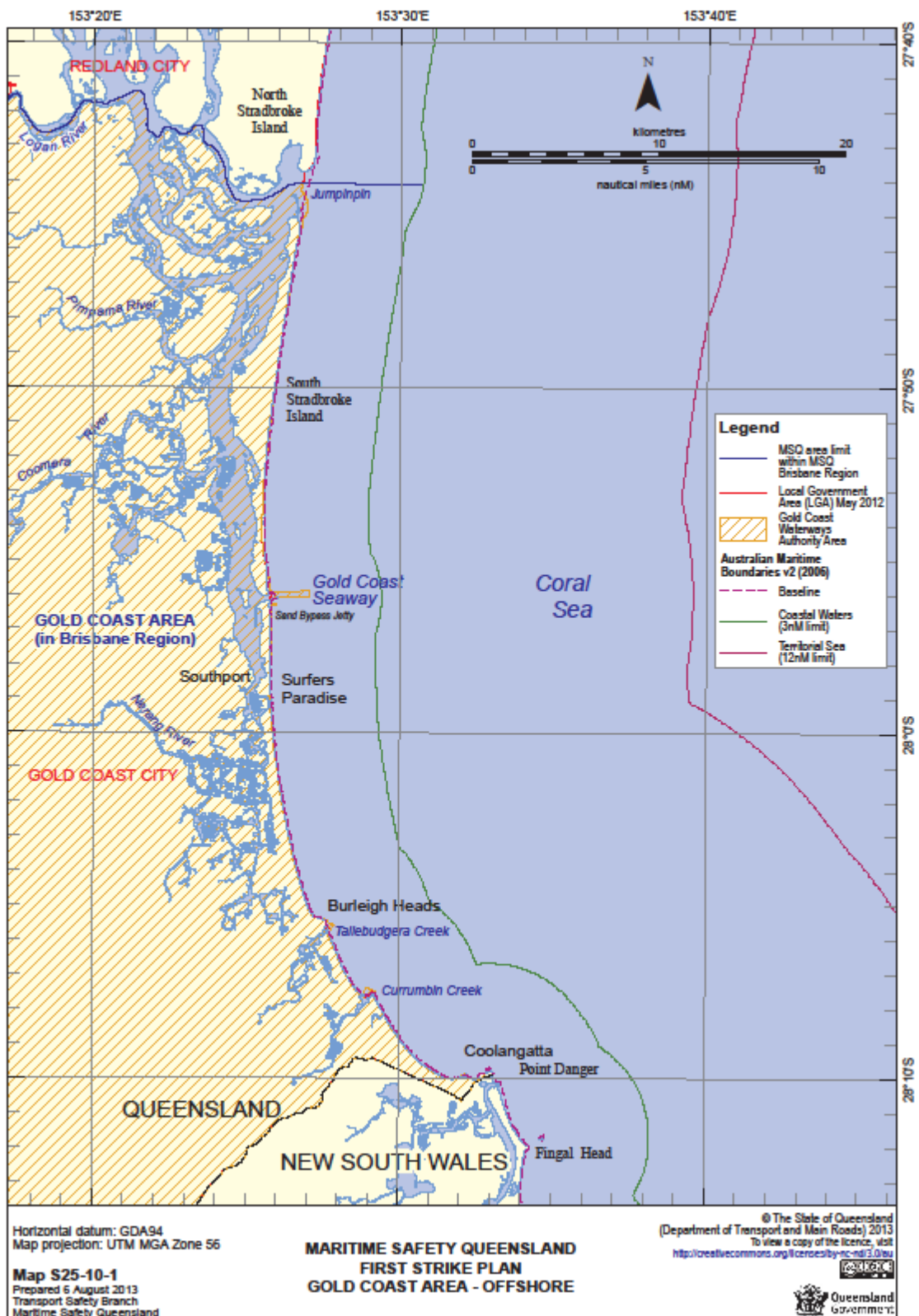

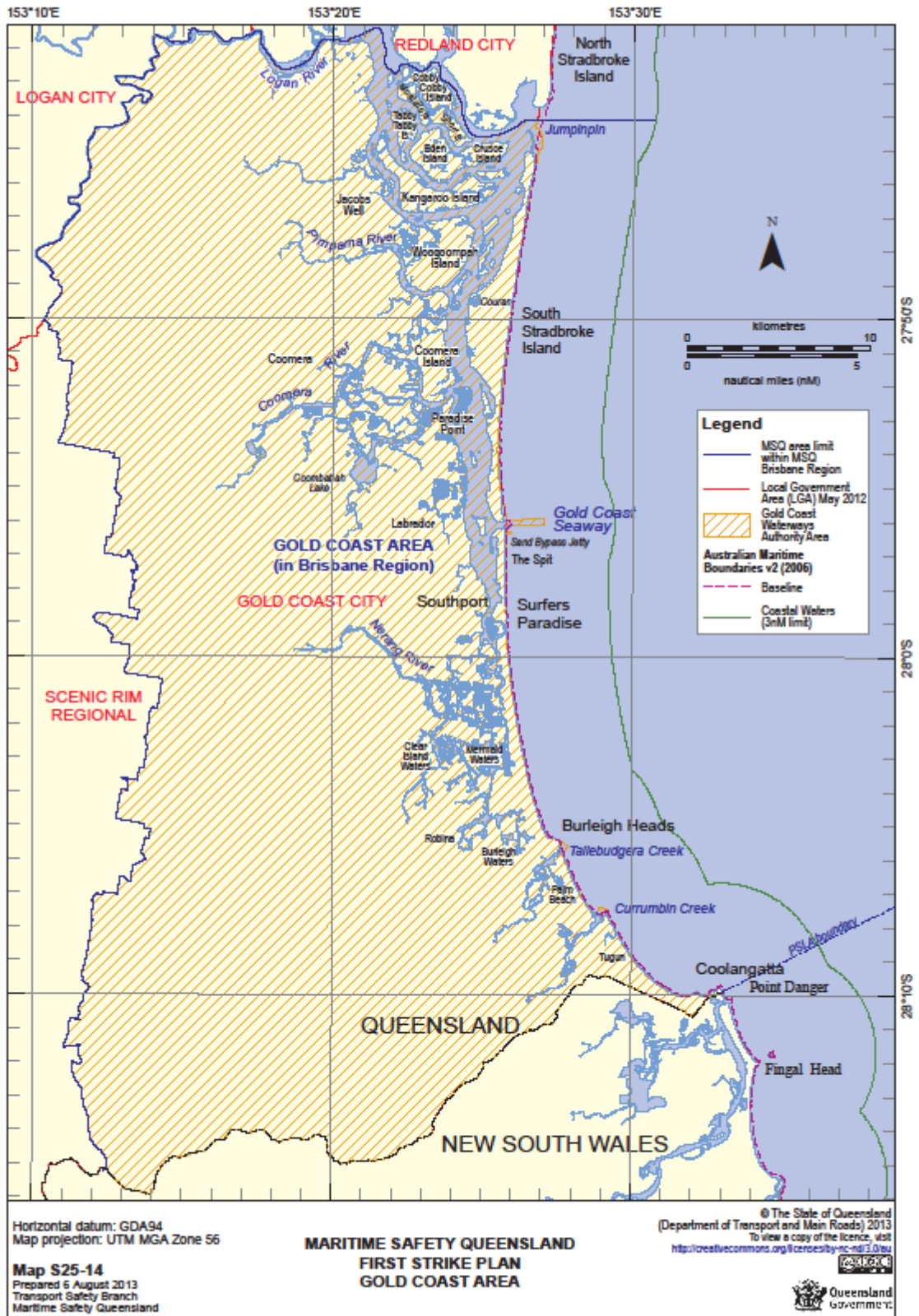

Appendix B – Map of Queensland/New South Wales border region

