

Uniform Shipping Laws Code 2008

Section 7: Load Lines

(CTH, NSW, NT, QLD, SA, TAS, VIC & WA)

This is not the official version of the Uniform Shipping Laws Code.
The official version is that last published by the Australian Government Publishing Service, Canberra, copies of which can be obtained from the National Marine Safety Committee.

SECTION 7 LOAD LINES

CONTENTS

1. This section is divided into parts as follows:

Part 1.	Preliminary	3
Part 2.	Conditions of Assignment	10
Part 3.	Strength and Stability of Vessels	19
Part 4.	Initial Surveys	19
Part 5.	Calculation and Assignment of Freeboards	21
Part 6.	Marking of Load Lines and Associated Marks	32
Part 7.	Periodical Surveys and Periodical Inspections	34
Part 8.	Extension of Load Line Certificates	35
Part 9.	Cancellation of Certificates	36
Part 10.	Appropriate Load Lines	36
Part 11.	Modifications Applicable to Vessels operating within Smooth and Partially Smooth Waters	37
Part 12.	Application to Existing Vessels	41
Part 13.	Issue of Certificates	41
Appendix A	Assumptions for Flooding Calculations	44
Appendix B	Tabular Freeboard for Type A Vessels	46
Appendix C	Tabular Freeboard for Type B Vessels	47
Appendix D	Provisions for Determination of Appropriate Load Lines - Clause 68	48
Appendix E	50	
Appendix F	51	
Appendix G	52	
Appendix H	53	

PART 1. PRELIMINARY

2. This Section should be read in conjunction with the Introduction, Definitions and General Requirements Section.
 3. In this Section, unless the contrary intention appears, the following definitions apply:
 - 3.1 '*After perpendicular*' means a line drawn at the after end of the vessel parallel to, and at a distance equal to the length of the vessel from, the forward perpendicular for the vessel.
 - 3.2 '*Amidships*' means the vertical plane situated half way between the perpendiculars of the vessel and at right angles to the centre line plane of the vessel.
 - 3.3 '*Assigning authority*' means -
In a case where an application is made to a survey authority for the assignment of freeboards - the survey authority to which the application is made.
 - 3.4 '*Flush deck vessel*' means a vessel that has no superstructure on the freeboard deck.
 - 3.5 '*Forward perpendicular*' means a line drawn at right angles to the waterline used for the purpose of ascertaining the length of the vessel at the intersection of the waterline with the fore side of the stem of the vessel.
 - 3.6 '*Perpendiculars*' means the forward and after perpendiculars.
 - 3.7 '*Summer moulded draught*' means the distance equal to the difference between:
 - (a) the actual depth to the deck line position of the vessel; and
 - (b) the summer freeboard assigned to the vessel in accordance with clause 46 of this Section.
 - 3.8 '*Superstructure deck*' means a deck forming the top of a superstructure.
 - 3.9 '*Survey authority*' means a survey authority authorised in writing by the Authority to issue certificates under this Section.
 - 3.10 '*The actual depth to the deck line position*' means the distance measured vertically amidships from the line from which the moulded depth of the vessel is, by sub-clause 3.18 of this Section, measured to the deck line position.
 - 3.11 '*The deck line position*' means the position of the line that, under clause 52 of this Section, constitutes, or is to constitute, the deck line for the vessel.
 - 3.12 '*Type A vessel*' means a vessel:
 - (a) that is designed to carry only liquid cargoes in bulk;
 - (b) that has a high integrity of the exposed deck by reason of the fact that its cargo tanks have only small access openings closed by watertight gasketed covers of steel or equivalent material; and
 - (c) that has a high degree of safety against flooding, resulting from the low permeability of loaded cargo spaces and the degree of sub-division provided being, in the case of a vessel that exceeds 150 metres in length, a degree of safety against flooding that is not less than that referred to in clause 33 of this Section.
 - 3.13 '*Type B vessel*' means a vessel other than a Type A vessel.
 - 3.14 '*Weathertight*' in relation to a fitting in a vessel, means that in any sea conditions water will not penetrate into the vessel through that fitting.
 - 3.15 '*Vessel*' does not include:
 - (a) a vessel of less than 24 metres measured length as defined in 3.16;
 - (b) a fishing vessel; and
 - (c) a vessel operating solely on the basis of the maximum number of passengers permitted to be carried being a smooth water vessel or a partially smooth water vessel.
- (Amendment dated March 1996)*
- 3.16 '*Length*' unless otherwise specified shall be read as a reference to:

- (a) a distance equal to 96 per cent of the total length of the vessel measured on a waterline that is:
 - (i) in the case of a vessel other than a vessel referred to in either of the next two paragraphs - at a distance, from the top of the keel, equal to 85 per cent of the least moulded depth of the vessel;
 - (ii) in the case of a wood vessel or a composite vessel - at a distance, from the lower edge of the keel rabbet, equal to 85 per cent of the least moulded depth of the vessel; or
 - (iii) in the case of a vessel in which the form at the lower part of the midship section is of a hollow character or in which thick garboards are fitted - at a distance, from the point where the line of the flat of the bottom continued inwards cuts the side of the keel of the vessel, equal to 85 per cent of the least moulded depth of the vessel; or
- (b) if the distance measured from the fore side of the stem to the axis of the rudder stock on that waterline is greater than the distance applicable under sub-clause 3.16 (a) that greater distance.

In the case of a vessel designed with a rake of keel, the waterline on which the total length of the vessel is to be measured for the purpose of sub-clause 3.16 (a) shall be parallel to the designed waterline.

- 3.17 *'Breadth of a vessel'* shall be read as a reference to its maximum breadth measured amidships to the moulded line of the frame if the vessel has a metal shell or to the outer surface of the hull if the vessel has a shell of any other material.
- 3.18 *'Moulded depth'*
 - 3.18.1 A reference to the moulded depth of a vessel at any part of the vessel shall, subject to this clause, be read as a reference to the vertical distance measured from the top of the keel to the top of the freeboard deck beam at side at that part and a reference to the least moulded depth of the vessel shall be read as a reference to the shortest of those distances.
 - 3.18.2 In the case of a wood vessel or a composite vessel, the reference in paragraph 3.18.1 to the top of the keel shall be read as a reference to the lower edge of the keel rabbet.
 - 3.18.3 In the case of a vessel in which the form at the lower part of the midship section is of a hollow character or thick garboards are fitted, the reference in paragraph 3.18.1 to the top of the keel shall be read as a reference to the point where the line of the flat of the bottom continued inwards cuts the side of the keel of the vessel.
 - 3.18.4 In the case of a vessel having rounded gunwales, the reference in paragraph 3.18.1 to the top of the freeboard deck beam at side shall be read as a reference to the point of intersection of the moulded lines of the deck and the side, the moulded lines being treated as extending as though the gunwale were of angular design.
 - 3.18.5 In the case of a vessel having a stepped freeboard deck, the raised part of which extends over the point at which the moulded depth is to be determined, the reference in paragraph 3.18.1 to the top of the freeboard deck beam at side shall be read as a reference to a line of reference extending from the lower part of the deck along a line parallel to the raised part.
- 3.19 *'Depth for freeboard'*
 - 3.19.1 A reference to the depth for freeboard of a vessel shall, subject to paragraph 3.19.3, be read as a reference to the moulded depth amidships of the vessel plus, if a freeboard deck stringer plate is fitted, the thickness of that plate and, if the exposed freeboard deck is sheathed from side to side with wood, plus the distance ascertained in accordance with the prescribed formula.
 - 3.19.2 For the purposes of paragraph 3.19.1, the prescribed formula is:
 - (a) in a case where the exposed freeboard deck is sheathed throughout its length, the formula:

$$T \frac{(L-S)}{L}; \text{ or}$$

(b) in any other case, the formula:

$$T \frac{l}{L}$$

Where:

T is the mean thickness in metres of the exposed sheathing clear of deck openings;

L is the length in metres of the vessel;

S is the total length in metres of superstructure as ascertained in accordance with sub-clause 3.26 of this section; and

l is the length in metres of the exposed freeboard deck that is sheathed.

3.19.3 In the case of a vessel having a rounded gunwale with a radius of greater than 4 per cent of the breadth of the vessel or having topsides of unusual form, a reference to the depth for freeboard of the vessel shall be read as a reference to the depth for freeboard, ascertained in accordance with this clause, of a vessel having a midship section with vertical topsides and with the same round of beam and with an area of topside section equal to that provided by the actual midship section.

3.20 'Block Coefficient' of a vessel shall be read as a reference to the number (C_b) ascertained in accordance with the formula:

$$C_b = \frac{\nabla}{LBd_1}$$

Where

B is the breadth of the vessel in metres;

d_1 is 85 per cent of the least moulded depth of the vessel in metres;

L is the length of the vessel in metres; and

Error! Objects cannot be created from editing field codes. is (a) if the vessel is a vessel with a metal shell the volume in cubic metres of the moulded displacement of the vessel, excluding bossing; or

(b) if the vessel is a vessel with a shell of any other material, the volume in cubic metres of displacement to the outer surface of the hull, Both taken at moulded draught of d_1 .

3.21 'Openings'

3.21.1 A reference to hatchways, doorways, ventilators or other opening in position 1 in a vessel shall be read as reference to hatchways, doorways, ventilation or other openings upon exposed freeboard decks and raised quarter decks or upon exposed superstructure decks situated forward of a point located a quarter of the length of the vessel abaft the forward perpendicular; and

3.21.2 A reference to hatchways, doorways, ventilators or other opening in position 2 in a vessel shall be read as reference to hatchways, doorways, ventilation or other openings upon exposed superstructure decks situated abaft of a point located a quarter of the length of the vessel abaft the forward perpendicular.

3.22 'Freeboard Deck'

3.22.1 A reference to the freeboard deck of a vessel shall, subject to this clause, be read as a reference to the uppermost complete deck, exposed to weather and sea, which has permanent means of closing all openings in the part exposed to the weather and below which all opening in the sides of the vessel are fitted with permanent means of watertight closing.

3.22.2 In the case of a vessel in which the uppermost complete deck exposed to the weather referred to in paragraph 3.22.1 is a discontinuous deck, the reference to the freeboard deck of the vessel shall be deemed to be a reference to a line of reference formed by the lowest line of that discontinuous deck and to the continuation of the line parallel to the upper part of that discontinuous deck.

- 3.22.3 The assigning authority may, at the request of the owner of the vessel specify that a lower deck, being a complete and permanent lower deck continuous in a fore and aft direction at least between the machinery space and peak bulkheads and continuous athwartships is to be the freeboard deck of the vessel, and, in that case, the reference to the freeboard deck of that vessel shall be read as a reference to the deck so specified.
- 3.22.4 Where the deck specified under paragraph 3.22.3 is stepped, the reference to the freeboard deck of the vessel shall be deemed to be a reference to a line of reference formed by the lowest line of the deck and the continuation of that line parallel to the upper part of the deck.
- 3.23 *'Superstructure'*
- 3.23.1 A reference to a superstructure of a vessel shall be read as a reference to a decked structure (including a raised quarter deck) on the freeboard deck extending from side to side of the vessel or with the side plating of the structure not being inboard of the shell plating by more than 4 per cent of the breadth of the vessel.
- 3.23.2 Where, in pursuance of paragraph 3.22.3, a lower deck is specified as the freeboard deck of a vessel, any part of the hull which extends above the deck so specified shall be deemed to be, for the purpose of this Section, a superstructure.
- 3.24 *'Enclosed superstructure'*
- 3.24.1 A reference to an enclosed superstructure shall be read as a reference to a superstructure with:
- (a) enclosing bulkheads of efficient construction;
 - (b) access openings, if any, in the bulkheads fitted with doors complying with the requirements of sub-clause 6.1; and
 - (c) all other openings in the sides or ends of the superstructure fitted with efficient weathertight means of closing.
- 3.24.2 A bridge or poop shall not be deemed to be an enclosed superstructure for the purposes of this Section unless means of access are provided for the crew to reach machinery and other working spaces inside the bridge or poop from the uppermost completely exposed deck or from a higher deck, being means available at all times when the access openings in the bulkheads enclosing the bridge or poop are closed.
- 3.25 *'Height of superstructure'*
- 3.25.1 A reference to the height of a superstructure shall be read as a reference to the least vertical height measured at side from the top of the superstructure deck beams to the top of the freeboard deck beams.
- 3.25.2 A reference to the standard height of a superstructure or trunk shall, subject to paragraph 3.25.3, be read as a reference to the standard height ascertained in accordance with the following table:

(Amendment dated October 1996)

<i>Length of Vessel</i>	<i>Standard Height</i>	
	<i>Raised Quarter Deck</i>	<i>All other superstructures</i>
<i>m</i>	<i>m</i>	<i>m</i>
30 or less	0.9	1.8
75	1.2	1.8
125 or more	1.8	2.3

- 3.25.3 A reference to the standard height of a superstructure or trunk in a vessel having a length that is between 30 metres and 75 metres or between 75 metres and 125 metres shall be ascertained by linear interpolation.

3.26 *'Length of superstructure'*

- 3.26.1 A reference to the length of a superstructure shall, subject to this clause be read as a reference to the mean length of the parts of the superstructure which lie within the length of the vessel.
- 3.26.2 Where the end bulkhead of an enclosed superstructure extends in a fair convex curve beyond its intersection with the superstructure sides, a reference to the length of the superstructure shall be read as a reference to the mean length increased by two-thirds of the fore and aft extent of the portion of superstructure formed by the curved bulkhead, and the maximum curvature that may be taken into account in determining the increase is one-half of the breadth of the superstructure at the point of intersection of the curved end of the superstructure with its side.
- 3.26.3 Where a superstructure bulkhead has a recess, whether decked over or not, the length of the superstructure shall be reduced by a distance ascertained by dividing the area of the recess by the breadth of the vessel at the middle of the length of the recess.
- 3.26.4 If the recess referred to in paragraph 3.26.3 is unsymmetrical about the centre line of the vessel, the area of the recess shall be deemed to be twice the area of the larger portion.
- 3.26.5 Where there is an extension to a superstructure having a breadth on each side of the centre line not less than 30 per cent of the breadth of the vessel the effective length of the superstructure shall be increased by an assumed equivalent superstructure bulkhead in the form of a parabola extending from the extension at the centre line passing through the junction of the actual superstructure bulkhead with the sides of the extension and extending to the sides of the vessel, or, if the superstructure is set in from the sides of the vessel, to the sides of the superstructure and being completely confined within the boundary of the superstructure and its extensions.

- 3.27 *'Effective length of enclosed superstructure'*.
- 3.27.1 A reference to the effective length of an enclosed superstructure of standard height or of a height greater than standard height shall, subject to this sub-clause, be read as a reference to the length of the superstructure.
- 3.27.2 Where an enclosed superstructure of standard height or of a height greater than standard height is set in from the sides of the vessel the reference to the effective length of an enclosed superstructure shall be read as a reference to the length of the superstructure modified in accordance with the ratio:
- $$\frac{b}{Bs}$$
- Where:
- b is the breadth of the superstructure at the middle of its length; and
Bs is the breadth of the vessel at the middle of the length of the superstructure.
- 3.27.3 Where an enclosed superstructure is set in for a part of its length, the modification referred to in paragraph 3.27.2 shall be applied only to the part that is set in.
- 3.27.4 Where the height of an enclosed superstructure is less than its standard height, the reference to the effective length of the enclosed superstructure shall be read as a reference to its length reduced in accordance with the ratio of its actual height to its standard height.
- 3.27.5 Where a raised quarter deck is fitted with an intact front bulkhead, the reference to the effective length of the superstructure shall be read as a reference to:
- (a) the length of the raised quarter deck; or
 - (b) if the length exceeds 60 per cent of the length of the vessel—60 per cent of the length of the vessel.
- 3.27.6 Where a raised quarter deck is fitted with a front bulkhead that is not intact, the raised quarter deck shall, for the purpose of this Section, be deemed to be a poop of less than standard height.
- 3.28 *'Unenclosed superstructure'*. A superstructure that is not enclosed does not have an effective length.
- 3.29 *'Trunk or similar structure'*.
- 3.29.1 A trunk or a similar structure in a vessel which does not extend to the sides of the vessel shall be deemed to be efficient if it complies with the following conditions:
- (a) the trunk or similar structure shall be at least as strong as a superstructure;
 - (b) any hatchways in the vessel in way of the trunk shall be in the trunk deck;
 - (c) the hatchway coamings and covers shall comply with the requirements of clauses 8 to 13 (inclusive) of this Section;
 - (d) the width of the trunk deck stringer shall be such as to provide a satisfactory gangway and sufficient lateral stiffness;
 - (e) permanent working platform fore and aft fitted with guard rails shall be provided by the trunk deck or by detached trunks connected to superstructures by efficient permanent gangways;
 - (f) ventilators shall be protected by the trunk and by watertight covers if the height of the ventilators is less than that specified in clause 17 of this Section;
 - (g) open rails shall be fitted on the weather parts of the freeboard deck in way of the trunk for at least half their length;
 - (h) the machinery casings shall be protected by the trunk, by a superstructure of at least standard height, or by a deckhouse of standard height and of equivalent strength;

- (i) the breadth of the trunk shall be at least 60 per cent of the breadth of the vessel; and
 - (j) where there is no superstructure, the length of the trunk shall be at least 60 per cent of the length of the vessel.
- 3.29.2 The effective length of an efficient trunk shall be the full length of that trunk reduced in accordance with the ratio of its mean breadth to the breadth of the vessel.
- 3.29.3 Where the height of an efficient trunk is less than its standard height, the effective length of that trunk shall be its effective length ascertained in accordance with paragraph 3.29.2 reduced in accordance with the ratio of its actual height to its standard height.
- 3.29.4 Where the height of hatchway coamings on the trunk deck is less than that required under sub-clause 8.1 of this Section, the reference in paragraph 3.29.3 to the actual height of the trunk shall be read as a reference to its actual height reduced by the difference between the actual height of the coamings and that height required by sub-clause 8.1 of this Section.
- 3.29.5 For the purpose of paragraphs 3.29.3 and 3.29.4 the standard height of a trunk is the standard height of a superstructure (other than a raised quarter deck).
- 3.29.6 Nothing in sub-paragraph 3.29.1(b) prevents a vessel from being provided with small openings on the freeboard deck if watertight covers for those openings are fitted.

PART 2. CONDITIONS OF ASSIGNMENT

4. Stability Information

- 4.1 This clause applies to a vessel whether the keel of the vessel was laid before or after the commencement of this Section.
- 4.2 There shall be carried at all times on a vessel to which this Section applies information with respect to the stability of the vessel, being information approved as information that satisfies the requirements of this Section and shall include particulars appropriate to the vessel in respect of all matters specified in clause A4 of the 'Stability Section'.
- 4.3 The information shall be based:
- (a) on the elements of the vessel determined by submitting the vessel to an inclining test, or, if the Authority is satisfied that reliable information with respect to the stability of the vessel can be obtained from the elements of the stability of a sister vessel determined when the sister vessel was submitted to an inclining test, on the elements of the stability, so determined, of the sister vessel; or
 - (b) in the case of a vessel specially designed for the carriage of liquids or ore in bulk, on the elements of the stability of the vessel determined by submitting the vessel to an inclining test, or the Authority is satisfied that, having regard to a vessel's proportions and arrangements and the elements of the stability of vessels of similar proportions and arrangements determined when those vessels were submitted to an inclining test, sufficient metacentric height will be maintained no matter how the vessel is loaded, on the elements of the stability, so determined, of those similar vessels.
- 4.4 Where alterations that materially affect the stability of a vessel to which this Section applies are made to the vessel in Australia or elsewhere, there shall be carried at all times on board the vessel after the alterations have been made revised information with respect to the stability of the vessel, being information approved as information that satisfies the requirements of Appendix G of this Section and based on:
- (a) the elements of the stability of the vessel or other vessel or vessels on which the information was based as affected by the alterations made to the vessel; or
 - (b) the elements of the stability of the vessel as altered determined by submitting the vessel as so altered to an inclining test.

5. Bulkheads at Exposed Ends of Enclosed Superstructures

- 5.1 Bulkheads at exposed ends of enclosed superstructures shall be of approved construction.

6. Access Openings in Bulkheads

- 6.1 The access openings in a bulkhead at the end of an enclosed superstructure shall be fitted with doors which shall, unless otherwise approved, open outwards, shall be so arranged that they can be operated from both sides of the bulkhead, shall be made of steel or other equivalent material, shall be permanently and strongly attached to the bulkhead and shall be so framed, stiffened and fitted that:
- (a) the whole structure is of a strength equivalent to that which the bulkhead would have if it was not pierced; and
 - (b) the whole structure is so constructed that, when those openings are closed, the structure is weathertight.
- 6.2 The doors so fitted in the openings in an end bulkhead shall be secured in a weathertight condition by gaskets and clamping devices permanently attached to the bulkhead or to the doors.
- 6.3 The height of the sills of access openings in bulkheads at the ends of the enclosed superstructure shall be at least 380 mm above the deck or, if another height above the deck is specified in this Part, that other height.
- 6.4 Unless otherwise approved, portable sills shall not be provided.

7. Cargo and other Hatchways

- 7.1 Cargo and other hatchways in position 1 and in position 2 in a vessel shall be closed only:
- (a) by portable covers supported by portable beams and secured weathertight by tarpaulins and battening devices; or
 - (b) by pontoon covers secured weathertight by tarpaulins and battening devices; or
 - (c) by weathertight covers made of steel or other equivalent material fitted with gaskets and clamping devices.

8. Coamings of Hatchways

- 8.1 The coamings of hatchways in position 1 and position 2 in a vessel shall be of substantial construction and, subject to this Section the height above the deck of coamings in position 1 shall be at least 600 mm and the height above the deck of coamings in position 2 shall be at least 450 mm.
- 8.2 Where:
- (a) hatchways in a vessel are closed by weathertight covers made of steel or other equivalent material fitted with gaskets and clamping devices; and
 - (b) the assigning authority is satisfied that the safety of the vessel in any sea conditions will not be impaired by so doing, the assigning authority may:
 - (c) determine that the coamings of those hatchways shall be of a height that is less than that specified in the last preceding sub-clause; or
 - (d) determine that coamings for those hatchways be omitted,
- and in such a case, the coamings shall be of the height so specified or the coamings may be omitted.

9. Appropriate assumed loads for Hatchways

- 9.1 For the purposes of sub-clauses 10.3, 10.4, 11.2 and 13.2 of this Section:
- (a) the appropriate assumed load for a hatchway in position 1 in a vessel 100 metres in length or over is 1.75 tonnes per square metre and for a hatchway in position 2 in such a vessel is 1.30 tonnes per square metre;
 - (b) the appropriate assumed load for a hatchway in position 1 in a vessel 24 metres in length is 1.0 tonnes per square metre and for a hatchway in position 2 in such a vessel is 0.75 tonnes per square metre; and
- (Amendment dated March 1996)*
- (c) the appropriate assumed load for a hatchway in position 1 or a hatchway in position 2 in a vessel the length of which is between 24 metres and 100 metres shall be obtained by linear interpolation.

10. Hatchway Covers

- 10.1 The width of each bearing surface in the case of hatchway covers secured weathertight by tarpaulins and battening devices shall be at least 65 mm.
- 10.2 Where such a hatchway cover is made of wood, the finished thickness shall be at least 60mm in association with a span of not more than 1.5 metres.
- 10.3 Where such a hatchway cover is made of mild steel:
- (a) the strength of the material shall be such that, when the maximum stress calculated by using an assumed load that is not less than the appropriate assumed load for a hatchway in the position in the vessel in which the hatchway is situated is multiplied by the factor 4.25, the result will not exceed the minimum ultimate strength of the material; and
 - (b) the hatchway cover shall be so designed as to limit the deflexion to not more than 0.0028 times the span under the appropriate assumed load.
- 10.4 Where a portable beam for supporting such a hatchway cover is made of mild steel:
- (a) the strength of the material shall be such that, when the maximum stress calculated by using an assumed load that is not less than the appropriated assumed load for a hatchway in the position in the vessel in which the hatchway is situated is

- multiplied by the factor 5, the result will not exceed the minimum ultimate strength of the material; and
- (b) the portable beam shall be so designed as to limit the deflexion to not more than 0.0022 times the span under the appropriate assumed load.
- 10.5 Carriers or sockets for portable beams used for supporting hatchway covers shall be of substantial construction and shall provide means for the efficient fitting and securing of the beams and, where rolling types of beams are used, the arrangement shall be such that the beams remain properly in position when the hatchway is closed.

11. Pontoon Covers

- 11.1 The width of each bearing surface in the case of a pontoon cover secured weathertight by tarpaulins and battening devices shall be at least 65 mm.
- 11.2 Where a pontoon cover is made of mild steel:
- (a) the strength of the material shall be such that, when the maximum stress calculated by using an assumed load that is not less than the appropriate assumed load for a hatchway in the position in the vessel in which the hatchway is situated is multiplied by the factor 5, the result will not exceed the minimum ultimate strength of the material;
 - (b) the pontoon covers shall be so designed as to limit the deflexion to not more than 0.0022 times the span under appropriate assumed load; and
 - (c) the mild steel plating forming the top of the pontoon cover shall have a thickness of not less than 1 per cent of the spacing of the stiffeners or 6 mm, whichever is the greater.
- 11.3 Where a pontoon cover is made of a material other than mild steel, the strength and stiffness of the pontoon cover shall be equivalent to that prescribed by the last preceding sub-clause for a pontoon cover of mild steel.

12. Tarpaulin Hatchway Covers

- 12.1 When the weathertightness of hatchway covers is secured by tarpaulins:
- (a) at least two layers of tarpaulin shall be provided for each hatchway;
 - (b) the tarpaulin shall be waterproof, of ample strength, of a material of approved standard weight and quality and in good condition;
 - (c) battens shall be efficient and in good condition;
 - (d) wedges shall:
 - (i) be efficient and in good condition;
 - (ii) be of tough wood, or other equivalent material;
 - (iii) have a taper of not more than 1 in 6; and
 - (iv) be not less than 13 mm thick at the toes;
 - (e) cleats shall:
 - (i) be set to fit the taper of the wedges;
 - (ii) be at least 65 mm in width;
 - (iii) be spaced not more than 600 mm centre to centre; and
 - (iv) the cleats along each side or end shall not be more than 150 mm from the hatch corners;
 - (f) in the case of a hatchway cover that is not more than 1.5 metres in length, at least one steel bar or other equivalent means shall be provided for the hatchway capable of efficiently and independently securing each section of hatchway cover after the tarpaulins are battened down; and
 - (g) in the case of a hatchway cover that is more than 1.5 metres in length, at least two steel bars or other means of the kind referred to in the last preceding paragraph shall be provided.

13. Steel Hatchway Covers

- 13.1 Where hatchways are secured weathertight by hatch covers of steel fitted with gaskets and clamping devices, the covers shall be of substantial construction.
- 13.2 Where such a hatchway cover is made of mild steel:

- (a) the strength of the material shall be such that when the maximum stress calculated by using an assumed load that is not less than the appropriate assumed load for a hatchway in the position in the vessel in which the hatchway is situated is multiplied by the factor 4.25, the result will not exceed the minimum ultimate strength of the material;
- (b) the hatchway cover shall be so designed as to limit the deflexion to not more than 0.0028 times the span under the appropriate assumed load; and
- (c) the mild steel plating forming the top of the cover shall have a thickness of not less than 1 per cent of the spacing of the stiffeners or 6 mm, whichever is the greater.

13.3 Where such a hatchway cover is made of material other than mild steel, the strength and stiffness of the cover shall be equivalent to that prescribed by the last preceding sub-clause for a cover of mild steel.

13.4 The means for securing and maintaining weathertightness shall be such that weathertightness will be maintained in any sea conditions.

14. Capacity of Coamings and Covers for Hatchways

14.1 Unless the assigning authority otherwise approves, coamings of hatchways and covers for hatchways on decks above the superstructure deck shall be capable of withstanding loads calculated on the basis set out in clause 9 of this Section for coamings of hatchways and covers for hatchways in position 2.

15. Openings

15.1 Machinery space openings in position 1 or in position 2 shall be properly framed and efficiently enclosed by steel casings of ample strength, the strength being determined according to the extent of the protection afforded to the casings by other structures.

15.2 Access openings in the steel casing shall be fitted with doors complying with the provisions of clause 6 of this Section and the sills of the doors shall be not less than 600 mm above the deck if in position 1, and not less than 380 mm above the deck if in position 2.

15.3 Other openings in the steel casings shall be fitted with equivalent covers permanently attached in their proper positions.

15.4 Subject to the next succeeding sub-clause, coamings of any fiddley, funnel or machinery space ventilator in an exposed position on the freeboard deck or superstructure deck shall be as high above the deck as is reasonable and practicable, and fiddley openings or openings into boiler and machinery spaces shall be fitted with strong covers of steel or other equivalent material permanently attached in their positions and capable of being secured weathertight.

15.5 The height above the deck of the coamings of any fiddley, funnel or machinery space ventilator in an exposed position on the freeboard deck or superstructure deck of a vessel shall not be less than:

- (a) if the fiddley, funnel or machinery space ventilator is in position 1 in the vessel—
900 mm; or
- (b) if the fiddley, funnel or machinery space ventilator is in position 2 in the vessel—
760 mm.

16. Protection of Openings

16.1 Manholes and flush scuttles in position 1 or in position 2 or within superstructures other than enclosed superstructures shall be closed by substantial covers capable of being made watertight and, unless secured by closely spaced bolts, the covers shall be permanently attached.

16.2 Openings in freeboard decks other than hatchways, machinery space openings, manholes and flush scuttles shall be protected by an enclosed superstructure, or by a deckhouse or companionway of equivalent strength and weathertightness.

- 16.3 Such an opening in an exposed superstructure deck or in the top of a deckhouse on the freeboard deck which gives access to a space below the freeboard deck or a space within an enclosed superstructure shall be protected by an efficient deckhouse or companionway and the doorways in such a deckhouse or companionway or the doorways to interior deck openings shall be fitted with doors complying with the provisions of sub-clauses 6.1 and 6.2.
- 16.4 Subject to sub-clause 16.5, the height above the deck of sills to the doorways in deckhouses or companionways shall be not less than 600mm in position 1, and not less than 380mm in position 2.
- 16.5 Where means of access from the uppermost complete exposed deck or from a higher deck are provided for the crew to reach machinery and other working spaces inside a bridge or poop that is an enclosed superstructure, the height above the deck of sills of doors in deckhouses or companionways in position 1 shall not be less than 380 mm.

17. Ventilator Coamings

- 17.1 Ventilators in position 1 or position 2 to spaces below the freeboard deck or the deck of an enclosed superstructure shall have coamings of steel or other equivalent material, substantially constructed and efficiently connected to the deck and, where the coaming of any ventilator exceeds 900 mm in height above the deck, it shall be specially supported.
- 17.2 Ventilators passing through superstructures other than enclosed superstructures shall have substantially constructed coamings of steel or other equivalent material at the freeboard deck.
- 17.3 Ventilator openings in vessels over 100 metres in length shall be provided with efficient weathertight closing appliances which shall be conveniently stowed near the ventilators to which they are to be fitted.
- 17.4 Ventilator openings in vessels of 100 metres or under in length shall be provided with efficient weathertight closing appliances which shall be permanently attached to the ventilators.
- 17.5 Ventilators in position 1 shall have coamings of a height of not less than 900mm above the deck and ventilators in position 2 shall have coamings of a height of not less than 760 mm above the deck unless, in the case of ventilators in exposed positions, the assigning authority directs that the coamings shall have a greater height above the deck and, if the assigning authority so directs, the coamings shall have that greater height.
- 17.6 Unless the assigning authority otherwise directs, sub-clauses 17.3 and 17.4 of this clause do not apply to ventilators in position 1, the coamings of which extend to more than 4.5 metres above the deck and, to ventilators in position 2, the coamings of which extend to 2.3 metres above the deck.

18. Air Pipes

- 18.1 Where air pipes to ballast and other tanks extend above the freeboard or superstructure decks, the exposed parts of the pipes shall be of substantial construction and the height from the deck to the point where water may have access below shall, subject to the next succeeding sub-clause, be not less than 760 mm on the freeboard deck and shall be not less than 450 mm on the superstructure deck.
- 18.2 Where the heights referred to in the last preceding sub-clause may interfere with the working of the vessel, the assigning authority may, if satisfied that the closing arrangements and other circumstances justify a lower height, specify heights lower than those specified in that sub-clause.
- 18.3 Satisfactory means, permanently attached, shall be provided for closing the openings of the air pipes.

19. Cargo Ports

- 19.1 Cargo ports and other similar openings in the sides of a vessel below the freeboard deck shall be fitted with doors so designed as to ensure watertightness and structural integrity commensurate with the surrounding shell plating, and the number of such openings shall be the minimum compatible with the design and proper working of the vessel.

- 19.2 The lower edge of the cargo ports and other openings shall not be below a line, drawn parallel to the freeboard deck at side, which has as its lowest point the upper edge of the uppermost load line assigned to the vessel.

20. Discharges, Inlets and Scuppers

- 20.1 Subject to sub-clause 20.6 each discharge led through the shell either from spaces below the freeboard deck or from within superstructures and deckhouses on the freeboard deck fitted with doors complying with the requirements of sub-clauses 6.1 and 6.2 shall be fitted with efficient and accessible means for preventing water from passing inboard.
- 20.2 Subject to sub-clauses 20.4 and 20.5, the means for preventing water from passing inboard referred to in sub-clause 20.1 shall consist of one automatic non-return valve with a positive means of closing it from a position above the freeboard deck in respect of each separate discharge.
- 20.3 The means for closing the valve referred to in sub-clause 20.2 shall be readily accessible at all times under service conditions and shall be provided with an indicator showing whether the valve is open or closed.
- 20.4 Where the vertical distance from the summer load waterline to the inboard end of a discharge pipe referred to in sub-clause 20.1 exceeds 1 per cent of the length of the vessel, the discharge may have two automatic non-return valves without positive means of closing provided that the inboard valve is always accessible for examination under service conditions.
- 20.5 Where the vertical distance from the summer load waterline to the inboard end of a discharge pipe referred to in sub-clause 20.1 exceeds 2 per cent of the length of the vessel, the discharge may have a single automatic non-return valve without positive means of closing.
- 20.6 Where a discharge associated with the operation of machinery is connected to a ship side discharge valve that is located within the machinery space and is readily accessible at all times, the provisions of sub-clauses 20.1 to 20.5 inclusive do not apply to the discharge.
- 20.7 In manned machinery spaces, main and auxiliary sea inlets and discharges in connection with the operation of machinery may be controlled locally and, if they are controlled locally, the controls shall be readily accessible and provided with indicators showing whether the valves are open or closed.
- 20.8 In a machinery space which may be unmanned for any period during the normal operation for the vessel at sea:
- (a) the main and auxiliary sea inlets and discharges in connection with the operation of machinery in the spaces may be controlled locally and, if they are controlled locally, the controls shall be readily accessible and provided with indicators showing whether the valves are open or closed; and
 - (b) the machinery space shall be fitted with an efficient warning device to give warning, at the position where the machinery is being monitored or controlled, of an entry of water into the machinery space other than water resulting from the normal operation of the machinery.
- 20.9 Scuppers and discharge pipes originating at any level and penetrating the shell either more than 450 mm below the freeboard deck or less than 600 mm above the summer load waterline shall be provided with a non-return valve at the shell.
- 20.10 The provisions of sub-clause 20.9 do not apply to a scupper or discharge pipe:
- (a) where the discharge pipe is associated with the operation of machinery and is connected to a ship side discharge valve that is located within the machinery space and that valve is readily accessible at all times; or
 - (a) except in the case of a discharge referred to in sub-clauses 20.1 to 20.6 inclusive, where the piping is of a thickness not less than:
$$\frac{\text{Diameter of pipe in mm}}{24} + 6.5 \text{ mm}$$
but need not exceed 12.5mm.

- 20.11 Scuppers leading from superstructures or deckhouses not fitted with doors complying with the requirements of sub-clauses 6.1 and 6.2 shall be lead overboard.
- 20.12 All shell fittings and valves required by this clause shall be of steel, bronze or other approved ductile material and shall not be of ordinary cast iron.
- 20.13 All pipes referred to in this clause shall be of steel or other equivalent material.

21. Side Scuttles

- 21.1 Side scuttles to spaces below the freeboard deck or to spaces within enclosed superstructures shall be fitted with efficient hinged inside deadlights arranged so that they can be effectively closed and secured watertight.
- 21.2 A side scuttle shall not be fitted in such a position that its sill is below a line drawn parallel to the freeboard deck at side and having its lowest point 2.5 per cent of the breadth or 500 mm above the load waterline, whichever is the greater distance.
- 21.3 The side scuttles, together with their glasses, if fitted, and deadlights, shall be of substantial and approved construction.
- 21.4 Where an opening in a superstructure deck or in the top of a deckhouse on the freeboard deck which gives access to a space below the freeboard deck or to a space within an enclosed superstructure is protected by an efficient deckhouse fitted with side scuttles, only those side scuttles that give direct access to an open stairway shall be fitted with deadlights in accordance with this clause.

22. Freeing Ports

- 22.1 Where bulwarks on the weather portions of a freeboard deck or a superstructure deck form wells, adequate provision shall be made for rapidly freeing and draining the decks of water.
- 22.2 For the purposes of this clause, adequate provision for rapidly freeing and draining the freeboard deck of water shall be deemed not to have been made unless there is provided on each side of the vessel in each well on that deck:
 - (a) a minimum freeing port area ascertained in accordance with the next seven succeeding sub-clauses; or
 - (b) if the assigning authority directs a greater minimum freeing port area in respect of the vessel on the ground that the minimum freeing port area so ascertained would be insufficient - a minimum freeing port area equal to the area so directed.
- 22.3 Where the sheer of the deck in which the well is situated is standard or greater than standard and the length of the bulwark in the well is 20 metres or less, the minimum freeing port area is an area having the same number of square metres as the number obtained by the formula:

$$0.7 + 0.035 \times l$$
- 22.4 Where the sheer of the deck in which the well is situated is standard or greater than standard and the length of the bulwark in the well exceeds 20 metres, the minimum freeing port area is an area having the same number of square metres as the number obtained by the formula:

$$0.07 \times l$$
- 22.5 Where the average height of the bulwark exceeds 1.2 metres, the area ascertained in accordance with whichever of the last two preceding clauses is applicable shall be increased by an area having the same number of square metres as the number ascertained in accordance with the formula:

$$0.04 \times l \times h_1$$
- 22.6 When the average height of the bulwark is less than 0.9 metres the area ascertained in accordance with whichever of sub-clauses 22.3 or 22.4 is applicable shall be reduced by an area having the same number of square metres as the number ascertained in accordance with the formula:

$$0.04 \times l \times h_2$$

- 22.7 For the purposes of the last four preceding sub-clauses:
- ‘l’ is the number equal to the number of metres in the length of the bulwark in the well, or if that length exceeds 0.7 times the length of the vessel, 0.7 of the length of the vessel;
- ‘h₁’ is the difference in metres between the average height of the bulwark in the well and 1.2 metres; and
- ‘h₂’ is the difference in metres between the average height of the bulwark in the well and 0.9 metres.
- 22.8 Where the deck in which the well is situated does not have any sheer, the minimum freeing port area on each side of the vessel in each well on the freeboard deck is an area equal to the area that would have been applicable under sub-clauses 22.3 to 22.6 inclusive, if the sheer of the deck had been standard plus 50 per cent of that last-mentioned area.
- 22.9 Where the sheer of the deck in which the well is situated is less than standard and clause 22.8 does not apply, the minimum freeing port area on each side of the vessel in each well on the freeboard deck is the area calculated in accordance with sub-clauses 22.3 to 22.6 inclusive, increased by a percentage obtained by linear interpolation, based on the sheer, between the area so calculated and the area ascertained in accordance with the last sub-clause.
- 22.10 The minimum freeing port on each side of the vessel in each well on a superstructure deck is one-half of the area that would have been applicable under the last seven preceding sub-clauses if that deck had been a freeboard deck.
- 22.11 Where a vessel fitted with a trunk is not fitted with open rails on the weather parts of the freeboard deck in way of the trunk for at least one-half of the length of the weather parts or where continuous or substantially continuous hatchway side coamings are fitted between detached superstructures, the minimum area of the freeing port openings in way of the trunk or coamings shall be calculated in accordance with the following table:

<i>Breadth of hatchway or trunk in relation to the breadth of vessel</i>	<i>Area of freeing ports in relation to the total area of the bulwarks</i>
40 per cent or less	20 per cent
75 per cent or more	10 per cent
Between 40 per cent and 75 per cent	The percentage obtained by linear interpolation

- 22.12 In vessels having superstructures which are open at either or both ends, adequate provision for freeing the space within those superstructures shall be provided.
- 22.13 The lower edges of the freeing ports shall be as near the deck as practicable, and two-thirds of the freeing port area required shall be provided in the half of the well nearest the lowest point of the sheer curve or, if there is no sheer in way of the well, the freeing port area shall spread along the length of the well.
- 22.14 All openings in the bulwarks referred to in this clause shall be protected by rails or bars spaced not more than 230 mm apart and, if shutters are fitted to freeing ports, ample clearance shall be provided to prevent jamming, hinges shall have pins or bearings of non-corrodible material, and securing appliances, if fitted to the shutters, shall be of approved construction.
- 22.15 In a flush deck vessel, a deckhouse the breadth of which is at least 80 per cent of the breadth of a vessel shall be deemed a superstructure for the purposes of this clause if the passages along the side of the deckhouse do not exceed 1.5 metres in width or if a screened bulkhead that is completely across the vessel is fitted at the forward end of the deckhouse.
- 22.16 For the purposes of sub-clause 22.10, a raised quarter deck shall be deemed to be a freeboard deck.

23. Protection for Crew

- 23.1 Deckhouses used for the accommodation of the crew shall be of adequate strength.
- 23.2 Efficient guard rails, or bulwarks, having a height of not less than 1 metre above the deck or such lesser height as is approved shall be fitted on all exposed parts of the freeboard and superstructure decks, first tier deckhouses and superstructure ends.
- 23.3 The opening below the lowest course of the guard rails shall not exceed 230 mm, the other courses being not more than 380mm apart and, in the case of vessels with rounded gunwales, the guard rail supports shall be placed on the flat of the deck.
- 23.4 Guard rails, life lines, gangways or underdeck passages shall be provided for the protection of the crew in getting to and from their quarters, the machinery space and all other parts used in the working of the vessel.
- 23.5 Deck cargo carried on any vessel shall be so stowed that any opening which is in way of the cargo and which gives access to and from the crew's quarters, the machinery space and all other parts used in the necessary work of the vessel can be properly closed and secured against the admission of water, effective protection for the crew in the form of guard rails or life lines being provided above the deck cargo if there is no convenient passage on or below the deck of the vessel.
- 23.6 This clause does not apply to an unmanned barge.

24. Special Conditions of Assignment for Type A Vessels

- 24.1 Machinery casings on Type A vessels shall be protected by an enclosed poop or bridge of at least standard height, or by a deckhouse of equal height and equivalent strength, but machinery casings may be exposed if there are no openings giving direct access from the freeboard deck to the machinery space and a door complying with the requirements of sub-clauses 6.1 and 6.2 may be permitted in the machinery casing if the door leads to a space or passageway which is as strongly constructed as the casing and is separated from the stairway to the engine room by a second weathertight door of steel or other equivalent material.
- 24.2 If a Type A vessel is fitted with a midship bridge or deckhouse, an efficiently constructed fore and aft permanent gangway of sufficient strength shall be fitted at the level of the superstructure deck between the poop and the midship bridge or deckhouse, or equivalent means of access shall be provided to carry out the purpose of such a gangway.
- 24.3 If a Type A vessel is not fitted with a midship bridge or deckhouse, arrangements shall be provided to safeguard the crew in reaching all parts used in the working of the vessel.
- 24.4 Safe and satisfactory access from the gangway level shall be available between different parts of the crew accommodation and between crew accommodation and the machinery space.
- 24.5 A Type A vessel with bulwarks shall have open rails fitted for at least half the length of the exposed parts of the weather deck or other effective freeing arrangements and the upper edge of the sheer strake shall be kept as low as practicable.
- 24.6 Where superstructures are connected by trunks, open rails shall be fitted for the whole length of the exposed parts of the freeboard deck.
- 24.7 Exposed hatchways on the freeboard deck and on the forecastle deck and on the top of expansion trunks in a Type A vessel shall be fitted with effective watertight covers of steel or other equivalent material and exposed hatchways in any other position shall be weathertight.

25. Provision of Loading Information

- 25.1 Unless the Authority has exempted a vessel or vessels included in a specified class of vessels from compliance with this clause, there shall be supplied on board a vessel sufficient information, in an approved form, to enable the master of the vessel to arrange for the loading and ballasting of the vessel in such a way to avoid the creation of any unacceptable stresses in the vessel's structure.

PART 3. STRENGTH AND STABILITY OF VESSELS

26. Strength and Stability Standards

- 26.1 Freeboards shall not be assigned to a vessel in accordance with Part 5 of this Section, unless the general structural strength of the vessel is sufficient to permit it to be loaded to draughts corresponding to the freeboards to be assigned to the vessel in accordance with that Part.
- 26.2 A vessel that has been built and maintained in accordance with the requirements of a survey authority shall be deemed to have the general structural strength required by sub-clause 26.1.
- 26.3 The design and construction of the vessel shall be such as to ensure that her stability in all probable loading conditions will be sufficient for the freeboard to be assigned to her and for this purpose regard shall be had, in addition to the intended service of the vessel, to the appropriate criteria contained in the Stability Section.
- 26.4 To determine whether the vessel complies with the requirements of sub-clause 26.3, the vessel shall, unless the Authority otherwise permits, be subject to an inclining test carried out in the presence of a surveyor appointed by the Authority and the Authority shall notify the assigning authority whether or not it is satisfied that the vessel complies with those requirements.

PART 4. INITIAL SURVEYS

27. Initial Survey

- 27.1 A vessel shall be subjected to an initial survey under this Part before it is first issued with a load line certificate.

28. Application for Initial Survey

- 28.1 An application for the initial survey of a vessel under this Part shall be made:
 - (a) if freeboards are to be assigned by the Authority, to the Authority;
 - (b) for the purpose of ascertaining that the arrangements, materials and scantlings apply, except to the extent that the Authority has exempted the vessel from compliance with the conditions of assignment specified in Part 2 of this Section, insofar as those conditions are applicable in relation to the vessel; and
 - (c) if the load line certificate in respect of the vessel was issued by an assigning authority, to that authority.
- 28.2 An application shall be accompanied by:
 - (a) a general arrangement plan;
 - (b) plans giving full details of:
 - (i) the transverse structure;
 - (ii) the longitudinal structure;
 - (iii) the stern frame, rudder and steering arrangements;
 - (iv) propeller shaft brackets;
 - (v) main engine seatings and main thrust seatings;
 - (vi) scuppers, discharges, sea inlets and tank venting, together with their associated piping; and
 - (vii) the structure and closing appliances of openings in the exposed freeboard deck, in any exposed freeboard deck, in any exposed superstructure deck, in an exposed deck above the superstructure deck, in a superstructure end bulkhead and in the vessel's sides;
 - (c) details showing arrangements for the protection of the crew;
 - (d) details showing sub-division arrangements and calculations; and
 - (e) intact and damage stability data, including:
 - (i) a capacity plan;
 - (ii) hydrostatic curves; and
 - (iii) cross curves of stability.

- 28.3 The Authority to which an application for a survey is made, may require the owner of a vessel who has made application for a survey to furnish such additional plans and information as the Authority considers necessary to enable the survey to be made and to enable load lines to be assigned to the vessel.
- 28.4 The Authority may exempt an applicant from compliance with any of the requirements of sub-clause 28.2 to the extent that he or it is satisfied that the furnishing of the plans or the information referred to in such a requirement is not necessary.

29. Inspection for Initial Survey

- 29.1 An initial survey shall consist of an inspection of the structure of the vessel and those parts of the equipment of the vessel that are referred to in Part 2 of this Section:
- (a) for the purpose of ascertaining that the structural strength of the vessel is not less than that referred to in sub-clause 26.1 and 26.2;
 - (b) for the purpose of ascertaining that the arrangements, material and scantlings comply, except to the extent that the Authority has exempted the vessel from compliance, with the conditions of assignment specified in Part 2, insofar as those conditions are applicable in relation to the vessel;
 - (c) for the purpose of the assignment of freeboards to the vessel in accordance with this Section; and
 - (d) for the purpose of ascertaining that it has been marked in accordance with Part 6.

30. Tests for Weathertightness and Watertightness

- 30.1 Where, by this Section, the means of closing hatchways and other openings in a vessel are required to be weathertight, or watertight, tests for weathertightness or watertightness, as the case may be, of those means shall be made at the initial survey of the vessel.

31. Documents to be Carried on a Vessel

- 31.1 At the initial survey of a vessel, the surveyor or survey authority shall ascertain whether or not:
- (a) the stability of information required under sub-clauses 4.1 to 4.4 inclusive is carried on board the vessel;
 - (b) the information referred to in clause 25 is carried on the vessel; and
 - (c) the statement referred to in sub-clause 76.1 is carried on the vessel.

PART 5. CALCULATION AND ASSIGNMENT OF FREEBOARDS

32. Assignment of Freeboards

- 32.1 Where an application has been made to the Authority for the assignment of freeboards and the surveyor reports that the vessel complies with the conditions of assignment applicable to the vessel under Part 2 of this Section and has the general structural strength referred to in Part 3, the Authority shall assign freeboards to the vessel in accordance with this Part or, in the case of a vessel the length of which is less than 24 metres, in accordance with this Part as modified under Part 11.
- 32.2 Where an application is made to a survey authority for the assignment of freeboards to a vessel and the survey authority is satisfied that the vessel complies with the conditions of assignment applicable to the vessel under Part 2 and has the general structural strength referred to in Part 4, the survey authority shall assign freeboards to the vessel in accordance with this Part or, in the case of a vessel the length of which is less than 24 metres, in accordance with this Part as modified under Part 11.
- 32.3 Where an application is made to the Authority or to a survey authority for the assignment of freeboards to a vessel, being freeboards greater than those which would, apart from this clause, be assigned to the vessel in accordance with this Part, the Authority or the survey authority, as the case may be, notwithstanding that the vessel does not comply with all the conditions of assignment applicable to the vessel under Part 2, may assign such greater freeboards as, in its opinion, are reasonable having regard to the extent to which the vessel complies with those conditions.

33. Type A Vessels

- 33.1 For the purposes of the assignment of freeboards, a vessel shall not, for the purposes of this Section, be deemed to be a Type A vessel unless:
- (a) in the case of a vessel that exceeds 150 metres in length but does not exceed 225 metres in length, and is so designed that, when loaded to the design summer load waterline, some compartments are filled and the remaining compartments are empty or partly filled, the vessel will be able to withstand the flooding of any one of those empty or partly filled compartments at an assumed permeability of 0.95;
 - (b) in the case of a vessel that exceeds 225 metres in length, is designed in the manner specified in the last preceding paragraph and is loaded in a manner referred to in that paragraph, the vessel shall be able to withstand the flooding of any one of the empty or partly filled compartments at an assumed permeability of 0.95, assuming that the machinery space in the vessel is a floodable compartment with an assumed permeability of 0.85; and
 - (c) when so flooded, the vessel will remain afloat in a condition of equilibrium.
- 33.2 For the purposes of sub-clause 33.1:
- (a) a vessel shall be deemed to be able to withstand the flooding of empty or partly filled compartments at an assumed permeability specified in sub-clause 33.1; and
 - (b) a vessel shall, when flooded to the extent referred to in sub-clause 33.1, be deemed to remain afloat in a condition of equilibrium,
- if, on the assumptions specified in Part I of Appendix A being made:
- (c) the angle of heel due to unsymmetrical flooding does not exceed 15 degrees or, if no part of the deck is immersed, the angle of heel due to unsymmetrical flooding does not exceed 17 degrees;
 - (d) with any part of the freeboard deck being immersed beyond the limits of flooding or with the margin of stability in the flooded condition being doubtful, the dynamic stability of the vessel is such that the righting lever curve has a minimum range of 20 degrees beyond the position of equilibrium in association with a righting lever of at least 100 mm; and
 - (e) the metacentric height of the vessel, after flooding and as calculated by the constant displacement method, is not less than 50 mm in the upright position.

34. Tabular Freeboards

- 34.1 The tabular freeboard for a Type A vessel:
- (a) that is of a length specified in Appendix B is the freeboard specified in that Appendix for a vessel of that length;
 - (b) that is of a length that is between any two consecutive lengths specified in Appendix B is the freeboard obtained by linear interpolation; and
 - (c) that exceeds 365 metres in length shall be such freeboard for a vessel of that length as the Authority determines.
- 34.2 Subject to clauses 35 to 37 inclusive, the tabular freeboard for a Type B vessel (including a lighter, barge or other vessel without independent means of propulsion):
- (a) that is of a length specified in Appendix C is the freeboard specified in that Appendix for a vessel of that length;
 - (b) that is of a length that is between any two consecutive lengths specified in Appendix C shall be obtained by linear interpolation; and
 - (c) that exceeds 365 metres in length shall be such freeboard for a vessel of that length as the Authority determines.
- 34.3 Where the tabular freeboard for a Type B vessel is reduced or increased in accordance with any of the clauses 35 to 37 inclusive, the tabular freeboard as so increased or reduced shall, for the purposes of clauses 38 to 41 inclusive, be deemed to be the tabular freeboard for the vessel.

35. Type B Vessels

- 35.1 In sub-clauses 35.2 to 35.7 inclusive a reference to a Type B vessel is to a Type B vessel that exceeds 100 metres in length.
- 35.2 Where the hatchways in position 1 and in position 2 in a Type B vessel are closed by weathertight covers made of mild steel or other equivalent material fitted with gaskets and clamping devices complying with the requirements of clause 13, the tabular freeboard for such a vessel may, if the vessel complies with the requirements of this clause, be reduced in accordance with this clause.
- 35.3 A Type B vessel shall not be assigned a reduction in freeboard under this clause unless:
- (a) the measures provided for the accommodation of the crew comply with the requirements of clause 23;
 - (b) the vessel is fitted with freeing arrangements in accordance with clause 22;
 - (c) in the case of a vessel in which coamings are not fitted to hatchways on the freeboard deck forward of a point located a quarter of the length of the vessel abaft the forward perpendicular, the strength and stiffness of the covers for those hatchways shall be not less than 15 per cent more than the strength and stiffness ascertained in accordance with sub-clause 13.2;
 - (d) the vessel, when loaded to its summer load waterline, will remain afloat in a satisfactory condition of equilibrium after flooding of any single damaged compartment at an assumed permeability of 0.95 excluding the machinery space; and
 - (e) in the case of a vessel of over 225 metres in length, the machinery space shall be treated as a floodable compartment but with a permeability of 0.85.
- 35.4 For the purposes of sub-clause 35.3, a Type B vessel shall be deemed to be a vessel that will remain afloat in a satisfactory condition of equilibrium when loaded and after flooding, to the extent referred to in sub-clause 35.3, if, on the assumptions specified in Part I of Appendix A being made, the results specified in sub-clauses 33.2 are obtained.
- 35.5 The reduction in the tabular freeboard for a Type B vessel which is by sub-clause 35.4 deemed to be a vessel that will remain afloat in a satisfactory condition of equilibrium is 60 per cent of the difference between the tabular freeboard specified in Appendix B for a vessel of the length of the Type B vessel and the tabular freeboard specified in Appendix C for a vessel of the length of the Type B vessel.

- 35.6 Where a Type B vessel complies with the requirements specified in sub-clause 35.3 and in addition:
- complies with the special conditions of assignment for a Type A vessel specified in sub-clauses 24.1 to 24.6 inclusive;
 - the vessel, when loaded to its summer load waterline and after flooding any two adjacent fore and aft compartments (not being machinery spaces) at an assumed permeability of 0.95, will remain afloat in a condition of equilibrium; and
 - in the case of a vessel that exceeds 225 metres in length, when loaded to its summer load waterline and after flooding the machinery space only at an assumed permeability of 0.85, will remain afloat in a condition of equilibrium;
- the reduction in the tabular freeboard to be allowed under this clause is the difference between the tabular freeboard specified in Appendix B for a vessel of the length of the vessel and the tabular freeboard specified in Appendix C for a vessel of the length of the vessel.
- 35.7 For the purposes of sub-clause 35.6, a Type B vessel shall be deemed to be a vessel that will remain afloat in a condition of equilibrium if, on the assumptions specified in Part I of Appendix A, as modified in accordance with Part II of Appendix A being made, the results specified in sub-clause 33.2 are obtained.

36. Type B Vessels With Hatchways Secured Weathertight by Tarpaulins etc.

- 36.1 Where the hatchways in position 1 in Type B vessels are fitted with portable covers supported by portable beams and secured weathertight by tarpaulins and battening devices complying with the requirements of clause 10, the tabular freeboard applicable to the vessel under clause 34 shall be increased:
- in the case of a vessel of a length specified in the table in this clause, by the freeboard increase specified in that table for a vessel of that length;
 - in the case of a vessel having a length that is between any two consecutive lengths specified in that table, by a freeboard increase obtained by linear interpolation; and
 - in the case of a vessel over 200 metres in length, by such freeboard increase for a vessel of that length as the Authority determines.

<i>Length of Vessel</i>	<i>Freeboard Increase</i>	<i>Length of Vessel</i>	<i>Freeboard Increase</i>	<i>Length of Vessel</i>	<i>Freeboard Increase</i>
<i>m</i>	<i>mm</i>	<i>m</i>	<i>mm</i>	<i>m</i>	<i>mm</i>
108 and below	50	139	175	170	290
109	52	140	181	171	292
110	55	141	186	172	294
111	57	142	191	173	297
112	59	143	196	174	299
113	62	144	201	175	301
114	64	145	206	176	304
115	68	146	210	177	306
116	70	147	215	178	308
117	73	148	219	179	311
118	76	149	224	180	313
119	80	150	228	181	315
120	84	151	232	182	318
121	87	152	236	183	320
122	91	153	240	184	322
123	95	154	244	185	325

124	99	155	247	186	327
125	103	156	251	187	329
126	108	157	254	188	332
127	112	158	258	189	334
128	116	159	261	190	336
129	121	160	264	191	339
130	126	161	267	192	341
131	131	162	270	193	343
132	136	163	273	194	346
133	142	164	275	195	348
134	147	165	278	196	350
135	153	166	280	197	353
136	159	167	283	198	355
137	164	168	285	199	357
138	170	169	287	200	358

37. Type B Vessels - Increase in Freeboard for Short Superstructures

- 37.1 The tabular freeboard, applicable under clause 34 as increased under the last preceding clause, if applicable, for a Type B vessel of not more than 100 metres in length, having enclosed superstructures with an effective length of up to 35 per cent of the length of the vessel, shall be increased in accordance with the following formula:

$$7.5(100 - L) \left(0.35 - \frac{E}{L} \right) \text{ mm}$$

Where

L is the length of the vessel in metres; and

E is the effective length of superstructure in metres.

38. Block Coefficient Correction

- 38.1 Where the block coefficient for a vessel exceeds 0.68, the tabular freeboard for the vessel or, if that freeboard has been modified in accordance with the preceding provisions of this Part, that tabular freeboard as so modified shall be increased to the distance equal to the distance ascertained by multiplying that freeboard by the following factor:

$$\frac{C_b + 0.68}{1.36}$$

where:

C_b is the block coefficient for the vessel.

39. Depth Correction

- 39.1 Where the depth for freeboard of a vessel exceeds a distance in metres equal to one-fifteenth part of the length of the vessel, the tabular freeboard for the vessel or, if that freeboard has been modified in accordance with the preceding provisions of this Part, that tabular freeboard as so modified shall be increased in accordance with the following formula:

$$\left(D - \frac{L}{15} \right) R \text{ mm}$$

where:

L is the length of the vessel in metres;

D is depth for freeboard of the vessel in metres; and

R is $\frac{L}{0.48}$ if the length of the vessel is less than 120 metres, or 250 if the length of the vessel is or exceeds 120 metres.

39.2 Where:

- (a) the depth for freeboard of the vessel is less than a distance in metres equal to one-fifteenth part of the length of the vessel; and
- (b) the vessel has an enclosed superstructure covering at least 60 per cent of the length and placed on either side of amidships, or has a complete trunk or combination of detached enclosed superstructures and trunks which extend all fore and aft,
- (c) the freeboard shall be reduced in accordance with the formula specified in sub-clause 39.1.

39.3 Where the height of the superstructure or trunk is less than its standard height, the reduction in the freeboard referred to in sub-clause 39.2 shall be made in accordance with the ratio of its actual height to its standard height.

40. Superstructure Correction

40.1 The tabular freeboard for a vessel or, if that freeboard has been modified in accordance with the preceding provisions of this Part, that tabular freeboard as so modified shall be reduced in accordance with sub-clauses 40.2 to 40.5 inclusive.

40.2 Where the total of the effective lengths of superstructures and trunks of the vessel is equal to the length of the vessel, the deduction shall be:

- (a) 265 mm in the case of a vessel the length of which is 16 metres;
- (b) 350 mm in the case of a vessel the length of which is 24 metres;
- (c) 860 mm in the case of a vessel the length of which is 85 metres;
- (d) 1070 mm in the case of a vessel the length of which is 122 metres or over; and
- (e) in the case of a vessel the length of which is an intermediate length, such distance as is ascertained by linear interpolation.

(Amendment dated March 1996)

40.3 Where the total of the effective lengths of superstructures and trunks in a vessel is less than the length of the vessel, the deduction shall, subject to the succeeding provisions of this clause, be a percentage ascertained in accordance with whichever of the following tables is applicable:

Percentage of Deduction for Type A Vessels

	<i>Total effective length of Superstructures and Trunks</i>										
	0	0.1L	0.2L	0.3L	0.4L	0.5L	0.6L	0.7L	0.8L	0.9L	1.0L
Percentage of deductions for all types of superstructures	0	7	14	21	31	41	52	63	75.3	87.7	100

Percentage of Deductions for Type B Vessels

	<i>Total effective length of Superstructures and Trunks</i>											
	<i>Line</i>	0	0.1L	0.2L	0.3L	0.4L	0.5L	0.6L	0.7L	0.8L	0.9L	1.0L
Vessels with forecastle and without detached bridge	I	0	5	10	15	23.5	32	46	63	75.3	87.7	100
Vessels with forecastle and detached bridge	II	0	6.3	12.7	19	27.5	36	46	63	75.3	87.7	100

40.4 For a Type B vessel, the percentage of deduction shall be ascertained in accordance with the following provisions:

- (a) where the effective length of a bridge is less than 20 per cent of the length of the vessel, the percentage shall be ascertained by linear interpolation between lines I and II in the table for Type B vessels;

- (b) where the effective length of a forecastle is more than 40 per cent of the length of the vessel, the percentages shall be ascertained from line II in the table for Type B vessels; and
- (c) where the effective length of a forecastle is less than 7 per cent of the length of the vessel, the percentages in lines I and II in the table for Type B vessels shall be reduced in accordance with the following formula:

(Amendment dated October 1993)

$$5 \times \frac{(0.07L - f)}{0.07L}$$

Where:

- f is the effective length of the forecastle in metres; and
- L is the length of the vessel in metres.

40.5 Where the total effective lengths of superstructures and trunks are intermediate lengths, the reduction under sub-clause 40.3 shall be ascertained by linear interpolation.

41. Sheer Correction

- 41.1 The tabular freeboard for a vessel, or, if that freeboard has been modified in accordance with the preceding provisions of this Part, that tabular freeboard as so modified is, if the sheer of the vessel varies from the standard sheer for the vessel, subject to modification in accordance with sub-clauses 41.2 to 41.14 inclusive.
- 41.2 For the purposes of this clause, the ordinates of the standard sheer profile for a vessel are those ascertained in accordance with the following table:

Standard Sheer Profile (L in metres)

	<i>Station</i>	<i>Ordinate (in mm)</i>	<i>Factor</i>
After half	After perpendicular	25 (L/3 + 10)	1
	1/6L from A.P.	11.1 (L/3 + 10)	3
	1/3L from A.P.	2.8 (L/3 + 10)	3
	Amidships	0	1
Forward half	Amidships	0	1
	1/3L from F.P.	5.6 (L/3 + 10)	3
	1/6L from F.P.	22.2 (L/3 + 10)	3
	Forward perpendicular	50 (L/3 + 10)	1

- 41.3 For the purposes of the last preceding sub-clause:
L is the length of the vessel in metres;
A.P. is the after perpendicular; and
F.P. is the forward perpendicular.

(Amendment dated October 1993)

- 41.4 The sheer of the vessel shall:
 - (a) subject to the next three succeeding paragraphs, be measured from the freeboard deck at side to a line of reference drawn parallel to the keel through the sheer line amidships;
 - (b) in a vessel designed with a rake of keel, be measured from the freeboard deck at side to a line of reference drawn parallel to the design load waterline through the sheer line amidships;
 - (c) in a flush deck vessel and in a vessel with a detached superstructure, be measured from, the freeboard deck at side to a line of reference drawn parallel to whichever of the lines of reference referred to in either of the last two preceding paragraphs is applicable;

- (d) in a vessel with top sides of unusual form in which there is a step or break in the top sides, be measured from the equivalent deck line at side ascertained in accordance with paragraph 3.19.3 to whichever of the lines of reference is applicable under (a) or (b) above;
 - (e) in a vessel with a superstructure of standard height which extends along the whole length of the freeboard deck, be measured from the superstructure deck at side to a line of reference drawn parallel to the keel through the sheer line amidships on the superstructure deck or, if the vessel is designed with a rake of keel, to a line of reference drawn parallel to the design load waterline through the sheer line amidships on the superstructure deck; and
 - (f) in a vessel where the deck of an enclosed superstructure has at least the same sheer as that of the exposed freeboard deck, be measured at the superstructure deck in way of the enclosed portion of the freeboard deck.
- 41.5 The variation of the difference between the sheer profile of a vessel and the standard sheer profile of that vessel shall be made in accordance with the following provisions:
- (a) the four ordinates of the sheer profile of the vessel and of the standard profile for the vessel in the forward half and the after half shall be multiplied by the appropriate factors given in the table in sub-clause 41.2;
 - (b) the difference between the sum so ascertained in respect of the products obtained by the multiplication of the four ordinates in the forward half of the sheer profile of the vessel and the products obtained by the multiplication of the four ordinates in the standard sheer profile for the vessel divided by 8 measures the deficiency or excess of the sheer in the forward half of the vessel;
 - (c) the difference between the sum so ascertained in respect of the products obtained by the multiplication of the four ordinates in the after half of the sheer profile of the vessel and the products obtained by the multiplication of the four ordinates in the standard sheer profile for the vessel divided by 8 measures the deficiency or excess of the sheer in the after half of the vessel; and
 - (d) the arithmetical mean of the excess or deficiency so ascertained for the forward half and for the after half is, for the purposes of this clause, but subject to sub-clauses 41.6 and 41.7, the excess or deficiency, as the case requires, of the sheer of the vessel.
- 41.6 Where the after half of the sheer profile of the vessel has an excess of sheer and the forward half of the sheer profile has a deficiency of sheer, the excess in sheer obtained by the after half shall not be taken into account, and only the deficiency in the forward half shall be taken into account, for the purposes of this clause.
- 41.7 Where the forward half of the sheer profile of the vessel has an excess of sheer and the after half has a deficiency in sheer, the following provisions apply:
- (a) where the deficiency of sheer in the after half does not exceed 25 per cent of the standard sheer for the vessel, both the excess in sheer and the deficiency in sheer shall be taken into consideration for the purposes of this clause;
 - (b) where the deficiency in the sheer of the vessel in the after half exceeds 50 per cent of the standard sheer for the vessel, the excess in the forward half shall not be taken into account, and only the deficiency in the sheer in the after half shall be taken into account, for the purposes of this clause; and
 - (c) where the deficiency of the sheer in the after half of the vessel is between 50 per cent and 25 per cent of the standard sheer for the vessel, the excess sheer to an extent ascertained by linear interpolation shall be taken into consideration and the deficiency in sheer of the after half of the vessel shall be taken into consideration.
- 41.8 In the case of a vessel that has an enclosed poop or forecastle:
- (a) of standard height with a greater sheer than the sheer of the freeboard deck; or
 - (b) of a greater height than standard height; and
 - (c) being a vessel in respect of which the provisions of sub-clause 41.4 (f) have not been applied, the sheer of the freeboard deck shall be increased in accordance with the formula:

$$S = \frac{yL^1}{3L}$$

where:

- S is the amount in millimetres by which the sheer is to be increased;
- y is the difference between the actual height and the standard height of the superstructure at the end ordinate in millimetres;
- L¹ is the mean enclosed length of the poop or forecastle or, if that mean length exceeds 50 per cent of the length of the vessel, 50 per cent of the length of the vessel in metres; and
- L is the length of the vessel in metres.

- 41.9 Where the actual height of a poop or forecastle at the end ordinate exceeds the standard height for that poop or forecastle, a credit in the sheer of the vessel to be deducted from the deficiency or added to the excess of the sheer of the vessel ascertained in accordance with the preceding provisions of this clause shall be made in accordance with the formula:

$$S = \frac{yL^1}{3L}$$

where:

- S is the sheer credit in millimetres to be added or deducted
- y, L¹ and L have the same respective meanings as they have in the formula specified in sub-clause 41.8.

- 41.10 The curve ascertained in accordance with the application of the formula referred to in the last preceding sub-clause shall be in the form of a parabola tangent to the actual curve of the freeboard deck and intersecting the end ordinate of the freeboard deck at a point below the superstructure deck at a distance equal to the standard height of the poop or forecastle and so drawn that the distance of each point of the curve from the superstructure deck is not less than the standard height of the superstructure.
- 41.11 In the case where sub-clause 41.10 is applicable, the curve ascertained in accordance with that sub-clause shall be used for the purpose of determining the sheer profile of the forward half and the after half of the vessel instead of the actual sheer.
- 41.12 The modification to be made under this clause in the tabular freeboard for a vessel or in that freeboard as modified in accordance with the preceding provisions of this Part shall be the deficiency or excess of sheer for the vessel ascertained in accordance with the preceding provisions of this clause multiplied by:

$$0.75 - \frac{S}{2L}$$

where:

- S is the total length of the enclosed superstructure of the vessel; and
- L is the length of the vessel.

- 41.13 Where there is a deficiency in the sheer of a vessel ascertained in accordance with the preceding provisions of this clause, the modification ascertained in accordance with sub-clause 41.12 shall be added to the tabular freeboard for the vessel.
- 41.14 Where there is an excess in the sheer of the vessel ascertained in accordance with the preceding provisions of this clause, the following provisions apply:
- (a) in a vessel that has an enclosed superstructure covering 10 per cent of the length forward of amidships and 10 per cent of the length of the vessel abaft amidships, the modification for excess of sheer ascertained in accordance with sub-clause 41.12 shall be deducted from the freeboard;
 - (b) in a vessel in which there is no enclosed superstructure covering amidships, no deduction from the tabular freeboard shall be made under this clause;
 - (c) where an enclosed superstructure covers less than 10 per cent of the length of the vessel either forward or abaft amidships, the amount of the deduction from the tabular freeboard shall be obtained by linear interpolation; and
 - (d) the maximum deduction for excess sheer under this clause shall be at the rate of 125 mm for each 100 metres in the length of the vessel.

42. Bow Height Requirements

42.1 In this clause a reference to the bow height of a vessel shall be read as a reference to the vertical distance at the forward perpendicular between the waterline corresponding to the summer freeboard to be assigned to the vessel under this Part (other than any modification made in pursuance of this clause) and to the designed trim and the top of the exposed deck at side.

42.2 For the purposes of this clause, the minimum bow height of a vessel shall be ascertained:

- (a) in the case of a vessel the length of which does not exceed 250 metres, in accordance with the formula:

$$56L \left(1 - \frac{L}{500} \right) \left(\frac{1.36}{C_b + 0.68} \right) \text{ mm; or}$$

- (b) in the case of a vessel the length of which is 250 metres or over, in accordance with the formula:

$$7000 \left(\frac{1.36}{C_b + 0.68} \right) \text{ mm}$$

42.3 For the purposes of the last preceding sub-clause:

L is the length of the vessel in metres; and

C_b is the block coefficient or 0.68, whichever is the greater.

42.4 Where the bow height of a vessel is less than the minimum bow height ascertained in accordance with the sub-clause 42.2, the tabular freeboard for the vessel or, if that tabular freeboard has been modified in accordance with the preceding provisions of this Part, that tabular freeboard as so modified shall be increased by the difference between that minimum bow height and the bow height of the vessel.

42.5 Where:

- (a) part of the bow height of a vessel is obtained by sheer; and

- (b) the sheer extends aft for at least 15 per cent of the length of the vessel measured from the forward perpendicular,

that part of the bow height that is obtained by sheer shall be included in the measurement of the bow height of the vessel.

42.6 Where:

- (a) part of the bow height of a vessel is obtained by sheer; and

- (b) the sheer does not extend aft for at least 15 per cent of the length of the vessel measured from the forward perpendicular,

so much of the bow height obtained by sheer as the Authority determines shall be included in the bow height of the vessel.

42.7 Where part of the bow height of a vessel is obtained by a superstructure, that part of the bow height that is equal to the height of the superstructure shall not be taken into account for the purposes of this clause, unless:

- (a) the superstructure extends from the stem to a point at least 7 per cent of the length of the vessel abaft the forward perpendicular; and

- (b) the superstructure is an enclosed superstructure or, in the case of a vessel the length of which is over 100 metres, the superstructure is fitted with closing appliances approved by the assigning authority.

42.8 Where:

- (a) part of the bow height of a vessel is obtained by a superstructure; and

- (b) the superstructure does not extend from the stem to a point at least 7 per cent of the length of the vessel abaft the forward perpendicular,

so much of the bow height obtained by the superstructure as the Authority determines shall be included in the bow height of the vessel.

42.9 Notwithstanding the preceding provisions of this clause, the Authority may, in the case of a vessel designed for exceptional operations, specify that the minimum bow height of the vessel shall be such height as is determined by the Authority.

- 42.10 This clause does not apply to and in relation to an unmanned barge.
- 43. Modified Tabular Freeboard not to be less than 50 mm**
- 43.1 Where the tabular freeboard for the vessel as modified by the preceding provisions of this Part is less than 50mm, the tabular freeboard as so modified shall be deemed to be 50mm.
- 44. Tabular Freeboard as modified by clauses 35 to 42 to be not less than 150 mm**
- 44.1 Where:
- (a) a vessel has in position 1 hatchway with covers that do not comply with the requirements of clauses 11,13 and 24; and
 - (b) the tabular freeboard for the vessel as modified in accordance with the preceding provisions of this Part is less than 150 mm,
- the tabular freeboard for the vessel as modified by these provisions shall be deemed to be 150 mm.
- 45. Correction for Deck Line**
- 45.1 Where the actual depth to the deck line of a vessel exceeds the depth for freeboard of the vessel, the tabular freeboard for the vessel, or, if that freeboard has been modified in accordance with the preceding provisions of this Part, that freeboard as so modified shall be increased by a distance equal to the excess.
- 45.2 Where the depth for freeboard for a vessel exceeds the actual depth to the deck line of the vessel, the tabular freeboard for the vessel or, if the freeboard has been modified in accordance with the preceding provision of this Part, that freeboard as so modified shall be reduced by a distance equal to the excess.
- 46. Summer Freeboards for all Vessels including Sailing Vessels, Tugs, Wooden Vessels and Unmanned Barges**
- 46.1 Subject to this clause, the summer freeboard assigned to a vessel is the tabular freeboard for the vessel modified in accordance with the preceding provisions of this Part.
- 46.2 The summer freeboard to be assigned to a vessel designed to carry sail, whether as the sole means of propulsion or as the supplementary means of propulsion, and to a tug, shall be the tabular freeboard for the vessel, as modified in accordance with the preceding provisions of this Part, increased, if the Authority so determines having regard to the stability and strength of the vessel, to such extent as the Authority determines.
- 46.3 The summer freeboard to be assigned to a vessel:
- (a) of wood, of composite construction or of an approved material other than steel; or
 - (b) whose constructional features are such as to render the application of Part 2 unreasonable or impracticable, shall be the tabular freeboard modified in such manner as the Authority determines.
- 46.4 The summer freeboard to be assigned to an unmanned barge which has on the freeboard deck only small openings closed by watertight gasketed covers of steel or equivalent material is the tabular freeboard for the vessel as modified in accordance with the preceding provisions of this Part, reduced by 25 per cent.
- 47. Tropical Freeboard**
- 47.1 Subject to this clause, the tropical freeboard assigned to a vessel is the distance obtained by deducting from the summer freeboard for the vessel one forty-eighth part of the summer moulded draught of the vessel.
- 47.2 Where the tropical freeboard that would, but for this clause, be assigned to a vessel in accordance with sub-clause 47.1 would be less than 50 mm, the tropical freeboard for the vessel is 50 mm.
- 47.3 In applying sub-clause 47.2 in relation to a vessel, the summer freeboard for the vessel shall be ascertained as if clause 45 did not apply in relation to the vessel.
- 47.4 Where:
- (a) a vessel has in position 1 hatchway with covers that do not comply with the requirements of clauses 11,13 and 24; and

- (b) the tropical freeboard to be assigned to the vessel is less than 150 mm, the tropical freeboard to be assigned to the vessel shall be 150mm.

48. Winter Freeboard

- 48.1 The winter freeboard to be assigned to a vessel is the distance obtained by adding to the summer freeboard for the vessel one forty-eighth part of the summer moulded draught of the vessel.

49. Fresh Water Freeboards

- 49.1 The fresh water freeboard in summer to be assigned to a vessel is the distance obtained by deducting from the summer freeboard for the vessel a distance equal to the prescribed fresh water freeboard allowance.
- 49.2 The tropical fresh water freeboard to be assigned to a vessel is the distance obtained by deducting from the tropical freeboard for the vessel a distance equal to the prescribed fresh water freeboard allowance.
- 49.3 Subject to the next succeeding sub-clause, the prescribed fresh water freeboard allowance for a vessel is the distance ascertained in accordance with the following formula:

$$\frac{\Delta}{40T} \text{ cm}$$

Where

Δ is the displacement in salt water in tonnes at the summer load waterline; and

T is the tonnes per centimetre immersion in salt water at the summer load waterline.

- 49.4 Where the displacement of a vessel at the summer load waterline cannot be ascertained, the prescribed fresh water freeboard allowance for the vessel is one forty-eighth of the summer moulded draught for the vessel.

PART 6. MARKING OF LOAD LINES AND ASSOCIATED MARKS

50. Horizontal Mark

A reference in this Part to a horizontal mark shall be read as a reference to a mark the upper edge of which is parallel to the waterline used for the purposes of ascertaining the length of the vessel.

51. Marks on Each Side of Vessel

Where freeboards have been assigned to a vessel in accordance with the last preceding Part or Part 11, there shall be marked in accordance with this Part on each side of the vessel:

- (a) a mark specifying the deck line for the vessel (Fig. 1) (Appendix E or Appendix F whichever is applicable);
- (b) the load line mark for the vessel (Fig. 2) (Appendix E or Appendix F whichever is applicable);
- (c) marks being the seasonal marks referred to in clause 54 or such only of those marks as the assigning authority, on the application of the owner of the vessel, specifies to be the marks to be marked on the vessel (Fig. 2) (Appendix F); and
- (d) marks being the marks corresponding to the freeboards for partially smooth (PSW) or smooth water (SW), determined by the assigning authority on the application of the owner of the vessel and specified by that authority to be the marks marked on the vessel (Fig. 2) (Appendix E).

52. Deck Line

- 52.1 The deck line for the vessel is the upper edge of a horizontal mark, 300 mm in length and 25 mm in breadth, which shall, subject to sub-clauses 52.2 and 52.3 be so placed that its upper edge shall pass through the point where the continuation outwards of the upper surface of the freeboard deck amidships intersects the outer surface of the shell.
- 52.2 Where the freeboard deck is sheathed amidships, the upper edge of the horizontal mark referred to in the last preceding sub-clause shall pass through the point where the continuation outwards of the upper surface of the sheathing amidships intersects the outer surface of the shell.
- 52.3 Where the assigning authority is satisfied that it is not practicable to mark the horizontal line in the position referred to in whichever of sub-clauses 52.1 and 52.2 is applicable, the upper edge of the horizontal mark referred to in this sub-clause shall pass through such other point amidships as the assigning authority directs.

53. Load Line Disc and Mark

- 53.1 The load line mark shall consist of a circular mark 25 mm in breadth and having an outside diameter of 300 mm, intersected by a horizontal mark 450 mm in length and 25 mm in breadth.
- 53.2 The circular mark shall be so placed that its centre is at a point vertically below the point that is the middle of the upper edge of the deck line for the vessel and, subject to sub-clause 53.4, at a distance from the upper edge of the deck line equal to the summer freeboard assigned to the vessel.
- 53.3 The horizontal mark forming part of the load line mark shall be so placed that the center of its upper edge is at the point which is the centre of the circular mark.
- 53.4 Where, at the request of the owner of a vessel, the summer freeboard that is assigned to the vessel is greater than or equal to the winter freeboard that would, but for the request of the owner, have been assigned to the vessel, the circular mark forming part of the load line mark shall be so placed that its centre is amidships vertically below the deck line at a distance not less than the winter freeboard that would have been assigned to the vessel.

54. Seasonal Load Line Marks

- 54.1 Each of the seasonal marks referred to in sub-clauses 54.2 to 54.5 inclusive shall be a horizontal mark 230 mm in length and 25 mm in breadth, extending from, and at right angles to a vertical mark 25 mm in breadth, placed forward of the circular mark in such a position that the nearest point of the vertical mark to the centre of the circular mark is at a distance of 540 mm from that centre.

- 54.2 The summer load line for a vessel is the upper edge of the horizontal mark forming part of the load line mark and a mark which:
- (a) shall be placed forward of the vertical mark referred to in sub-clause 54.1;
 - (b) shall be so placed that its upper edge if continued would pass through the centre of the circular mark in the load line mark for the vessel; and
 - (c) shall be marked with the letter 'S'.
- 54.3 The winter load line for a vessel is the upper edge of a mark which:
- (a) shall be placed forward of the vertical mark referred to in sub-clause 54.1 and below the summer load line for the vessel;
 - (b) shall be so placed that its upper edge is at a distance from the summer load line for the vessel equal to the difference between the summer freeboard assigned to the vessel, and the winter freeboard assigned to the vessel; and
 - (c) shall be marked with the letter 'W'.
- 54.4 The tropical load line for a vessel is the upper edge of a mark which:
- (a) shall be placed forward of the vertical mark referred to in sub-clause 54.1 and above the mark the upper edge of which is the summer load line for the vessel;
 - (b) shall be so placed that its upper edge is at a distance from the summer load line for the vessel equal to the difference between the summer freeboard assigned to the vessel and the tropical freeboard assigned to the vessel; and
 - (c) shall be marked with the letter 'T'.
- 54.5 The fresh water load line in summer for a vessel is the upper edge of a mark which:
- (a) shall be placed abaft the vertical mark referred to in sub-clause 54.1 and above the continuation of the summer load line for the vessel;
 - (b) shall be so placed that the distance from its upper edge to the continuation of the summer load line for the vessel is equal to the difference between the summer freeboard assigned to the vessel and the fresh water freeboard in summer assigned to the vessel; and
 - (c) shall be marked with the letter 'F'.

55. Sailing Vessels - Load Line Marks

- 55.1 Notwithstanding anything contained in the preceding provisions of this Part, a sailing vessel shall be marked with a deck line, and load line mark.
- 55.2 The deck line and the load line mark shall be marked on a sailing vessel in accordance with the provisions of clauses 52 and 53.
- 55.3 The upper edge of the horizontal line forming part of the load line mark on a sailing vessel is the summer load line for the vessel.

56. Assigning Authority Marks

- 56.1 The mark of the assigning authority by which the freeboards are assigned to a vessel may be marked above, or above and below the horizontal line that forms part of the load line mark and alongside the circular mark forming part of that mark.
- 56.2 The mark referred to in sub-clause 56.1 shall consist of not more than four initials indicating the name of the assigning authority.
- 56.3 An initial marked in accordance with this clause shall not exceed 115 mm in height and 75 mm in breadth. The marks required by this Part to be marked on a vessel shall be marked as illustrated in Figures 1 and 2 of Appendix E or Appendix F, whichever is applicable, being permanently embossed on or cut into the side of the vessel and painted in white or yellow if the background of the vessel is dark in colour, or in black if the background of the vessel is light in colour.

PART 7. PERIODICAL SURVEYS AND PERIODICAL INSPECTIONS

- 57. A vessel shall be subjected to a periodical survey under this Part whenever it is necessary to issue a load line certificate in respect of the vessel, being a certificate which is to take effect after the expiration of the period for which an existing load line certificate is in force.**
- 58. Making of an Application for a Periodical Survey**
- 58.1 An application for a periodical survey of a vessel in accordance with this Part shall be made:
- (a) if the load line certificate in respect of the vessel was issued by the Authority, to the Authority; or
 - (b) if the load line certificate in respect of the vessel was issued by a survey authority, to the survey authority.
- 58.2 The assigning authority to which an application under this clause is made may require the applicant to furnish such plans and information as are necessary for the purposes of the survey.
- 58.3 Notwithstanding the preceding provisions of this clause, an application for a periodical survey may be made to an assigning authority other than the assigning authority by which the load line certificate in respect of the vessel was previously issued and, in such a case, the application shall comply with the requirements of clause 28.
- 59. A periodical survey under this Part shall consist of an inspection of the structure of the vessel and those parts of the equipment of the vessel that are referred to in Part 2:**
- (a) for the purpose of ascertaining whether or not the structural strength of the vessel has deteriorated to such an extent that it is less than that referred to in clause 26;
 - (b) for the purpose of ascertaining that the arrangements, material and scantlings comply, except to the extent that the authority has exempted the vessel from compliance, with the conditions of assignment specified in Part 2 so far as those conditions are applicable in relation to the vessel;
 - (c) for the purpose of ascertaining whether any alteration to the freeboards previously assigned to the vessel is necessary;
 - (d) for the purpose of ascertaining whether the vessel is marked in accordance with Part 6; and
 - (e) for the purpose of ascertaining whether or not alterations have been made to the hull or superstructure of the vessel.
- 60. Periodical Inspection**
- 60.1 A vessel in respect of which a load line certificate is in force shall be subjected to a periodical inspection during each prescribed period that occurs during the period for which the load line certificate is in force.
- 60.2 For the purposes of sub-clause 60.1, each period commencing three months before the anniversary of the date specified in the load line certificate for the vessel as the date of the initial survey or of the last preceding periodical survey and ending three months after that anniversary is a prescribed period.
- 61. Purpose of Periodical Inspection**
- 61.1 A periodical inspection referred to in the last preceding clause shall be an inspection of the vessel for the purpose of ascertaining:
- (a) whether or not alterations have been made to the hull or superstructure, being alterations of such a nature that the summer freeboard specified in the load line certificate is no longer the summer freeboard to be assigned under these clauses to the vessel; and
 - (b) whether or not the fittings and appliances for the protection of openings, for the guard rails, for freeing ports and for means of access to crews' quarters are maintained in an effective condition.
- 61.2 Subject to sub-clause 61.3, each periodical inspection shall:
- (a) if the load line certificate for the vessel was issued by the Authority be carried out by a surveyor appointed by the Authority; or

- (b) in the case where the load line certificate was issued by a survey authority be carried out by the survey authority by which it was issued.
- 61.3 On an application made by or on behalf of the owner of a vessel, a periodical inspection under this clause may be carried out by an assigning authority other than the assigning authority by which the load line certificate for the vessel was issued.
- 62. **Where, by these clauses, the means of closing hatchways and other openings in a vessel are required to be weathertight or watertight, tests for weathertightness or watertightness, as the case may be, of those means shall be made at each periodical survey of the vessel.**
- 63. **At each periodical survey and periodical inspection of a vessel, the surveyor or survey authority shall ascertain whether or not:**
 - (a) the stability information required under clause 4 is carried on board the vessel;
 - (b) the information referred to in clause 25 of this Section is carried on the vessel; and
 - (c) the statement referred to in sub-clause 76.1 is carried on the vessel.

PART 8. EXTENSION OF LOAD LINE CERTIFICATES

- 64. **Alterations to Hull or Superstructures**
 - 64.1 Where, after a periodical survey referred to in clause 57, it is not for any reason practicable for the assigning authority by which the survey was carried out to issue a load line certificate before the expiration of the certificate in force in respect of the vessel at the date of the survey, the assigning authority by which the survey was carried out may extend the load line certificate in force at the date of survey for such period not exceeding five months as is specified by endorsement on that load line certificate.
 - 64.2 Where, as a result of a periodical survey referred to in clause 57, it is not, for any reason practicable for the assigning authority by which the survey was carried out to issue an International Load Line Exemption Certificate before the expiration of the certificate in force in respect of the vessel at the date of the survey, the assigning authority by which the survey was carried out may extend the International Load Line Exemption Certificate in force at the date of survey for such period not exceeding five months as is specified by endorsement on that load line exemption certificate.
 - 64.3 An extension shall not be granted if material alterations have been made to the hull or superstructure of the vessel, the equipment referred to in Part 2, the arrangements, material or scantlings, being alterations of such a nature that the summer freeboard specified in the load line certificate in force in respect of the vessel is no longer the summer freeboard to be assigned under this Section to the vessel.

PART 9. CANCELLATION OF CERTIFICATES

- 65.** The Authority shall cancel a load line certificate, if:
- (a) material alterations have been made to the hull or superstructure of the vessel, being alterations of such a nature that the summer freeboard specified in the load line certificate is no longer the summer freeboard to be assigned under this Section to the vessel;
 - (b) the conditions of:
 - (i) fittings and appliances for the protection of openings;
 - (ii) guard rails;
 - (iii) freeing ports; and
 - (iv) means of access to crew's quarters,are not maintained in an effective condition;
 - (c) the load line certificate is not endorsed to show that a periodical inspection of the vessel has been made in accordance with clause 60; or
 - (d) the structural strength of the vessel is lowered to such an extent that the vessel is unsafe.
- 66.** The Authority shall cancel a load line exemption if:
- (a) the International Load Line Certificate in respect of the vessel is cancelled under clause 65; or
 - (b) the vessel does not comply with the safety requirements as specified by the Authority when the exemption was granted by the Authority.
- 67.** Where the Authority cancels a load line exemption certificate on the ground specified in clause 66
- (b) it shall cancel the load line certificate issued in respect of the vessel.

PART 10. APPROPRIATE LOAD LINES

- 68.** The appropriate load line is the load line marked on the vessel that is specified, in whichever of the provisions of Appendix D that are applicable at the time in relation to the vessel, to be the appropriate load line for that vessel at that time.

**PART 11. MODIFICATIONS APPLICABLE TO VESSELS OPERATING WITHIN
SMOOTH AND PARTIALLY SMOOTH WATERS**

69. Modifications of this Section in its Application to Vessels Operating within Smooth and Partially Smooth Waters

69.1 In its application to and in relation to a vessel operating within smooth and partially smooth waters, this Section applies to such a vessel subject to such modifications as the Authority having regard to the strength and stability of the vessel determines.

69.2

- (a) The height above the deck of sills in doorways of deckhouses or superstructures on the weather deck from inside which there is direct access to spaces below the weather deck shall be not less than 300 mm;
- (b) The height above the deck of sills in doorways of deckhouses or superstructures or companionways on the weather deck which are shielded from the full force of the sea, except those giving direct access to machinery spaces shall be not less than 150 mm;

69.3 The coamings of hatchways in position (1) and (2) shall be of substantial construction. The height above deck of coamings in positions (1) and (2) shall be 300 mm.

(Amendment dated March 1996)

69.4 Where hatches, situated within the mid half beam of the vessel are of a width less than half the beam of the vessel and are closed with efficient weathertight covers of steel or other equivalent material fitted with gaskets and clamping devices and capable of being rapidly closed and battened down and the assigning authority is satisfied that the safety of the vessel in the service sea conditions will not be impaired by so doing, the assigning authority may:

- (a) determine that the coamings of these hatchways shall be of a height less than that specified in the above sub-clauses; or
 - (b) determine that coamings for those hatchways be omitted,
- and in such a case the coamings shall be of the height so specified or the coamings may be omitted.

69.5 Scuppers and discharge pipes which pass through the side of the vessel shall comply with the following:

- (a) Scupper and discharge pipes, excluding machinery exhaust systems, shall be fitted with screw down valves or cocks in an easily accessible position against the vessel's side, except that where approved bilge alarms are fitted, such valves or cocks shall not be required in the case of discharges not exceeding 40 mm internal diameter, the lowest point of which is not less than 225 mm above the summer load waterline. Waste and soil discharges greater than 40 mm internal diameter from spaces above the freeboard deck which are led through the vessel's side more than 225 mm above the summer load waterline may be fitted with a non-return valve in lieu of a screw down valve or cock;
- (b) Main propulsion machinery exhaust systems shall be fitted with an approved hull fitting the lower edge of which shall be as high as practicable but not less than 225 mm above the summer load waterline.
Such systems may pass through watertight bulkheads aft of the machinery space provided that:
 - (i) an after peak bulkhead is fitted extending to the weather deck;
 - (ii) the system is passed through the bulkhead or bulkheads as close to the underside of the weather deck as practicable; and
 - (iii) an approved bulkhead fitting is provided at each watertight bulkhead through which the system passes;
- (c) Auxiliary machinery exhaust systems shall comply with the provisions of sub-clause 69.5 (b) but shall not pass through watertight bulkheads without the approval of the Authority.

69.6 Where bulwarks in the weather portion of a freeboard deck form wells, and the sheer in the way of the well is standard or greater than standard, there shall be provided, on each side of the vessel, in each well a minimum freeing port area having the same number of square metres as the number:

- (a) where the length of the well is 20 metres or greater, obtained by the formula:
Freeing port area = $0.07 \times l$
where l = length of well in metres; or
- (b) where the length of the well is less than 20 metres, obtained from the following table:

(Amendment dated October 1993)

<i>Length of well (metres)</i>	<i>Freeing Port Area (each bulwark, metres²)</i>
2.5	0.28
5.0	0.52
7.5	0.72
10.0	0.90
12.5	1.07
15.0	1.21
17.5	1.32
20.0	1.40

The freeing port area for intermediate lengths of well may be determined by interpolation.

Corrections for bulwark height and sheer shall be made in accordance with the requirements of sub-clause 22.5 to 22.9 inclusive.

(Amendment dated October 1993)

69.7 The height of solid bulwark and rail shall not be less than 0.9 metres.

(Amendment dated March 1996)

69.8 Stability information to be carried on board as prescribed by sub-clause 4.2 and clause 25 shall take the form of guidance notes for the Master, as prescribed in paragraph A.4.1.23 of the Stability Section.

69.9 In the case of a vessel less than 24 metres in length, in applying the superstructure correction in accordance with clause 40, where the total of the effective lengths of superstructure and trunks of the vessel is equal to the length of the vessel, the deduction shall be:

- (a) 265 mm in the case of a vessel the length of which is 16 metres; and
- (b) $265 + (L-16) 10.625$ mm in the case of a vessel the length of which exceeds 16 metres but does not exceed 24 metres.

70. Freeboards for Barges and Lighters and Similar Vessels Operating Within Partially Smooth Waters

70.1 Barges and lighters and similar vessels operating within partially smooth waters or within restricted geographical limits nominated by the Authority may, upon the request of the owner, be assigned a restricted service load line while operating within those limits. The minimum freeboard to be assigned to these vessels shall be derived from this clause.

Tabular Freeboard

<i>Length</i>	<i>Freeboard (mm)</i>		<i>Standard sheer ordinate (m)</i>		<i>Standard Depth L/16 (m)</i>
	<i>Deck Barges and Scows</i>	<i>Hold barges and Lighters</i>	<i>Forward perpendicular</i>	<i>After perpendicular</i>	
24	94	121	1.108	0.554	1.50

30	140	178	1.258	0.629	1.87
35	190	228	1.383	0.691	2.18
40	246	270	1.508	0.754	2.5
45	300	320	1.634	0.817	2.81
50	360	360	1.758	0.879	3.12
55	424	424	1.883	0.941	3.44
60	475	475	2.009	1.004	3.75
65	526	526	2.134	1.067	4.06
70	584	584	2.259	1.129	4.38
75	643	643	2.384	1.192	4.69

Correction to tabular freeboard for variations from standard sheer and depth are given in sub-clauses 70.2 to 70.11 inclusive.

(Amendment dated March 1996)

- 70.2 Where a Raised Quarter Deck or break is fitted extending side to side, the after sheer ordinate to be used in deriving the freeboard shall be:

$$\text{Equivalent sheer ordinate} = \text{actual sheer ordinate} + \frac{(l \times h) \times 6}{L}$$

Where:

l = length of RQD or break in metres;

L = length of vessel in metres; and

h = height of RQD or break in metres.

Where the Raised Quarter Deck or break does not extend from side to side but covers not less than 75 per cent of the breadth, the equivalent sheer ordinate shall be:

Equivalent sheer ordinate = actual sheer ordinate + **Error! Objects cannot be created from editing field codes.**

- 70.3 Where the actual sheer profile aft modified as necessary in accordance with the preceding sub-clause differs from the standard parabolic sheer profile, an equivalent parabolic after sheer ordinate shall be calculated as follows:

$$\text{Equivalent after sheer ordinate (m)} = 6 \times \frac{\text{Area of actual after sheer profile in m}^2}{L}$$

Where

L = length in metres.

- 70.4 Where the actual sheer profile forward differs from the standard parabolic sheer profile, an equivalent parabolic forward sheer ordinate shall be calculated as follows:

$$\text{Equivalent forward sheer ordinate (m)} = 6 \times \frac{\text{Area of actual forward sheer profile in m}^2}{L}$$

Where

L = length in metres.

- 70.5 Where the actual sheer ordinate forward or the equivalent sheer ordinate forward determined by the preceding sub-clause is greater or less than standard, the tabular freeboard shall be reduced or increased respectively by an amount equal to:

1/8 x (difference between standard sheer ordinate and actual or equivalent sheer ordinate forward)

- 70.6 Where the actual sheer ordinate aft or the equivalent sheer ordinate as determined by sub-clauses 70.2 and 70.3 is less than half the standard sheer ordinate aft, the tabular freeboard shall be increased by an amount equal to:

$$\frac{(\frac{1}{2} \times \text{standard sheer aft}) - (\text{actual or equivalent sheer ordinate aft})}{4}$$

4

- 70.7 Where the actual sheer ordinate aft or the equivalent sheer ordinate as determined by sub-clauses 70.2 and 70.3 is greater than the standard sheer ordinate aft, the tabular freeboard shall be reduced by an amount equal to:
 $1/8 \times (\text{actual or equivalent sheer ordinate aft} - \text{standard sheer ordinate aft})$
 except that if the actual forward sheer ordinate is less than standard, no deduction for excess sheer aft shall be allowed.
- 70.8 Where the actual sheer ordinate aft or the equivalent sheer ordinate as determined by sub-clauses 70.2 and 70.3 is less than standard ordinate aft but not less than half that standard ordinate, no correction shall be made.
- 70.9 The maximum deduction for excess sheer shall in no case exceed 40 mm.
- 70.10 The tabular freeboard shall be corrected for the amount of propelling power as follows:
- (a) when **Error! Objects cannot be created from editing field codes.** is not less than 1.8 and not more than 2.4 an addition of 15 mm should be made to the tabular freeboard corrected for sheer; or
 - (b) when **Error! Objects cannot be created from editing field codes.** is less than 1.8 an addition of 40 mm should be made to the tabular freeboard corrected for sheer.
- Where:
- Lm= Length measured (metres);
 B = breadth (metres); and
 D = moulded depth at midships (metres).
- 70.11 The tabular freeboard shall be corrected for variation from standard depth as follows:

$$\text{Final Freeboard} = \text{tabular freeboard corrected for sheer and power} \times \frac{\text{actual depth at midships}}{\text{standard depth}}$$
- 70.12 The vessels must conform to strength and survey requirements as laid down by the Authority.
- 70.13 Minimum GM allowing for any free surface corrections is as determined from sub-clause C.3.3 of the Stability Section.
- 70.14 The minimum bow height of 0.6 metres is also to be maintained. Bulwark of standard height may be used in lieu for vessels that have no sheer in the upper deck. This bulwark should extend aft at least 3 metres.
- 70.15 Any vessel that cannot meet the above requirements will be considered on its merits and an appropriate freeboard assigned by the Authority.

71. Freeboard for Barges, Lighters and Similar Vessels Operating Within Smooth Water Limits

- 71.1 This clause applies to all barges, lighters and similar vessels operating within smooth water limits that have a completely enclosed upper deck, or open vessels that have watertight hatch coamings of standard height. The vessels must conform to strength and survey requirements as laid down by the Authority.
- 71.2 The minimum freeboard assigned is 300 mm provided that, in addition to the above, the vessel satisfies the following stability criteria.
- 71.3 Minimum GM allowing for any free-surface corrections is as determined from sub-clause C.3.4 of the Stability Section.
- 71.4 Any vessel that cannot meet the above requirements will be considered on its merits and an appropriate freeboard assigned by the Authority.

PART 12. APPLICATION TO EXISTING VESSELS

72. Existing Vessels

- 72.1 Where a load line has been assigned to an existing vessel prior to the commencement of these requirements such load line shall be considered adequate for the purpose of these requirements.
- 72.2 Where an existing vessel has not previously been assigned a load line such vessel will be assigned a load line as determined by the Authority.
- 72.3 Where an existing vessel undergoes repairs to, alterations of, or modification of a part of the vessel referred to in the conditions of assignment applicable in relation to the vessel, then this Section shall apply in respect of such part, unless the Authority determines otherwise.

PART 13. ISSUE OF CERTIFICATES

73. Certificates and Exemption Certificates

- 73.1 Where a vessel, except to the extent of any exemption granted by the Authority, has been surveyed and marked in accordance with the conditions of assignment applicable to the vessel, the Authority or a survey authority authorised by the Authority to issue certificates, may issue in respect of the vessel a load line certificate in a form approved by the Authority; the form of the certificate shall be as set out in Appendix G.
- 73.2 Where a vessel is exempted from compliance with this Section or a provision of this Section, the Authority shall issue in respect of the vessel a load line exemption certificate of the form set out in Appendix H.
- 73.3 Subject to this Section, a load line certificate remains in force for such period as is specified in the certificate, being a period that does not expire later than five years after the date of issue of the certificate.
- 73.4 Where a load line certificate is cancelled, the certificate is of no force or effect after the Authority has given notice in writing of the cancellation to the owner, agent or master of the vessel in respect of which the certificate was issued.
- 73.5 Where a load line certificate has been cancelled, the Authority may require the owner or master of the vessel in respect of which the certificate was issued to deliver up the certificate to the Authority and the vessel may be detained until the requirement is complied with.
- 73.6 The master or owner shall not take a vessel to sea, or permit a vessel to be taken to sea, on any voyage from a port in Australia unless there is in force in respect of the vessel:
 - (a) a load line certificate; or
 - (b) a load line exemption certificate.

PART 14—OVERLOADING

74. Loading of Vessels - Submersion of Load Line

- 74.1 Where a vessel is so loaded at any time that, if the vessel were floating without a list in still salt water of a specific gravity of 1.025, the load line marked on either side of the vessel that is the appropriate load line at that time would be submerged, the vessel shall, for the purposes of this Part, be deemed to be overloaded, and to be overloaded to the extent to which that load line would be so submerged.
- 74.2 Where:
 - (a) a vessel is at any time engaged on, or is about to engage on a voyage during which, in the ordinary course, a load line marked on either side of the vessel (not being a load line that is the appropriate load line at that time) would, at some later time during the voyage, become the appropriate load line; and
 - (b) the vessel is so loaded at that first-mentioned time that, if the vessel were floating without a list in still salt water of a specific gravity of 1.025 and there were unloaded from the vessel the fuel

and other material that would, in the ordinary course, be consumed or discharged before that later time, that load line would be submerged,

the vessel shall for the purposes of this Part be deemed to be overloaded and to be overloaded to the extent to which that load line would be so submerged.

- 74.3 For the purposes of this Part, the load line marked on a vessel that is the appropriate load line at any time shall be determined in accordance with this Section.
- 74.4 If, except as permitted by or under this Part—a vessel that is overloaded goes to sea from or arrives at any port, or is on any voyage, the master and owner of the vessel are each guilty of an offence punishable upon conviction by a fine and by an additional fine not exceeding an amount calculated at the rate of such amount as is applicable to the vessel (having regard to the gross tonnage of the vessel if the vessel is a passenger vessel, or the deadweight tonnage of the vessel if the vessel is a cargo vessel) for each 25 mm or part thereof by which the vessel is overloaded.
- 74.5 It is a defence in proceedings for an offence against sub-clause 74.4 in respect of a vessel if it is proved that the circumstances giving rise to the offence were due only to a deviation or delay of the vessel caused solely by stress of weather or other circumstances which neither the master nor owner of the vessel could have prevented or forestalled.
- 74.6 Where:
- (a) a certificate that relates, in whole or in part, to load lines is in force in respect of a vessel; and
 - (b) a surveyor is not satisfied that any deck line or load line marked on the vessel is in the position specified for that line in the certificate,
- the vessel may be detained until he is satisfied that the line is in that position.
- 74.7 If a vessel has been marked with deck lines and load lines and it is not, except with reasonable cause, kept so marked, the owner and master of the vessel are each guilty of an offence punishable upon conviction.
- 74.8 If a vessel has been marked with deck lines and load lines and any person, except with reasonable cause conceals, removes, alters, defaces or obliterates, or suffers any person under his control to conceal, remove, alter, deface or obliterate any such mark, he is guilty of an offence punishable upon conviction.

PART 15—MISCELLANEOUS

75. No Structural Alterations to be Made to Vessels

- 75.1 Except with the approval of the assigning authority by which a load line certificate is issued and in accordance with the conditions specified in such an approval, no alterations shall be made in the structure of the vessel, to those arrangements and those parts of the equipment of the vessel that are referred to in Part 2, and to the materials or the scantlings of the vessel after the vessel has been surveyed in accordance with this Section.
- 75.2 An application for the approval of the assigning authority under sub-clause 75.1 shall be in writing and shall specify the nature of the alterations proposed to be made to the vessel.

76. Assignment of Freeboard - Statement

- 76.1 Where freeboards have been assigned to a vessel in accordance with this Section, the assigning authority shall forward to the owner of the vessel a statement setting out such of the conditions of assignment specified in Part 2 as are applicable to the vessel.
- 76.2 The master of a vessel shall carry on the vessel the statement referred to in sub-clause 76.1.

77. Assignment of Freeboard - Documents

- 77.1 Where a load line certificate in respect of a vessel is issued by a survey authority, the survey authority shall forward to the Authority:
- (a) a copy of the certificate;
 - (b) a statement setting out such of the conditions of assignment specified in Part 2 as are applicable to the vessel; and

- (c) a statement setting out the manner in which the freeboards assigned to the vessel have been computed.

78. Permissible Overloading

- 78.1 Where a vessel departs from a place of loading situated on a river or inland waters, the vessel is permitted to be overloaded to the extent of the weight of the fuel and other materials that will be consumed or discharged between the place of loading and the sea.

APPENDIX A ASSUMPTIONS FOR FLOODING CALCULATIONS

Part I Assumptions

1. It is to be assumed that the vessel in the intact condition has no trim.
2. It is to be assumed that the vertical extent of damage in all cases will be equal to the depth of the vessel at each flooded compartment, disregarding the buoyancy of any superstructure or deckhouse directly above the flooded compartment.
3.
 - (1) It is to be assumed that the transverse extent of the damage will be equal to one-fifth of the breadth of the vessel measured inboard from the side of the vessel perpendicularly to the centre line at the level of the summer load waterline.
 - (2) If damage of a lesser extent than that specified in the last preceding sub-item will result in a more severe condition, it is to be assumed that the transverse extent of the damage will be that lesser extent.
4. It is to be assumed that no main transverse bulkhead will be damaged and that the damage may be located between two transverse bulkheads bounding side tanks.
5.
 - (1) If, in a transverse bulkhead, there are steps or recesses of not more than 3 metres in length located within the extent of transverse penetration of damage assumed for the purposes of item 3 of Appendix A, it is to be assumed that the transverse bulkhead will be intact and that each of the adjacent compartments will be flooded singly.
 - (2) If, in a transverse bulkhead, there is a step or recess of more than 3 metres in length located within the extent of penetration of damage assumed for the purposes of item 3 of Appendix A, it is to be assumed that the two compartments adjacent to that bulkhead will be flooded.
6.
 - (1) If a double bottom or side tank is divided by a transverse bulkhead located more than 3 metres from a main transverse bulkhead, it is to be assumed that the bottom or side tank will be flooded.
 - (2) If such a side tank has openings into the holds, it is to be assumed that those holds will be flooded, whether or not the openings are fitted with closing appliances.
7.
 - (1) It is to be assumed that the final waterline after flooding, taking into account sinkage, heel and trim, will be below the lower edge of any opening through which progressive flooding may take place.
 - (2) It is to be assumed, without limiting the generality of the last preceding sub-item, but subject to the next succeeding sub-item, that air pipes and openings which are closed by means of weathertight doors or covers of a kind referred to in clause 13, or sub-clauses 17.3 or 17.4, will be openings, through which progressive flooding may take place.
 - (3) It is to be assumed that openings closed by means of manhole covers and flush scuttles of a kind referred to in clause 16, cargo hatch covers of the type referred to in paragraph (b) of the definition of 'Type A vessel', watertight doors which are to be secured closed while at sea, remotely operated sliding watertight doors and side scuttles of the non-opening type of the type referred to in clause 21 are openings through which progressive flooding will not take place.
8. If pipes, ducts or tunnels are situated within the extent of penetration of damage assumed for the purposes of item 3, it will be assumed that the arrangements are such that flooding will not thereby extend beyond the limits assumed for the calculations of the damaged conditions.
9.
 - (1) It is to be assumed that, in calculating the height of the centre of gravity of the vessel above the base line, an allowance for homogenous loading for all spaces designed to contain cargo and 50 per cent of the individual total capacity of all tanks and spaces fitted to contain consumable fluids and vessel's stores will be made.
 - (2) It is to be assumed that, in calculating the height of the centre of gravity of the vessel, corrections for free surfaces of liquids will be made and that those corrections will be made on the following assumptions:
 - (a) that, for each type of liquid, at least one transverse pair of tanks or a single centre line tank will have a free surface and that the tank or combination of tanks that are taken into account will be those where the effect of free surfaces is the greatest;
 - (b) that the remaining tanks will be either completely empty or completely filled and that the distribution of consumable liquids between those tanks will be effected so as to obtain the greatest height above the keel for the centre of gravity of the vessel;
 - (c) that the effect of free surface in compartments containing fluid cargoes which may exist in the normal full load condition will be taken into account;

- (d) that weights will be calculated on the basis of the following values for specific gravities:
- | | |
|-----------------|-------|
| Salt water | 1.025 |
| Fresh water | 1.000 |
| Oil fuel | 0.950 |
| Diesel oil | 0.900 |
| Lubricating oil | 0.900 |
- and
- (e) that tanks situated in the machinery compartments and designed to contain consumable liquids will not be floodable unless the dynamic stability is doubtful or the heeling moment due to unsymmetrical flooding of these tanks is appreciable.

Part II Modifications for Type B Vessels

- 1 The assumptions in Item 4 of Part I of Appendix A shall not be made.
- 2 In applying, for the purpose of sub-clause 35.7, the assumptions specified in Part I, it is to be assumed that the spacing between any two of the main transverse watertight bulkheads is not less than a distance of 3 metres plus 3 per centum of the length of the vessel, or a distance of 11 metres, whichever is the less and, if in fact the spacing between any two of the transverse bulkheads in a vessel is less than that distance, it is to be assumed that one of those bulkheads does not exist.

APPENDIX B TABULAR FREEBOARD FOR TYPE A VESSELS

<i>Length</i>	<i>Freeboard</i>	<i>Length</i>	<i>Freeboard</i>	<i>Length</i>	<i>Freeboard</i>	<i>Length</i>	<i>Freeboard</i>	<i>Length</i>	<i>Freeboard</i>	<i>Length</i>	<i>Freeboard</i>	<i>Length</i>	<i>Freeboard</i>
		71	720	121	1476	171	2281	221	2801	271	3133	321	3334
		72	733	122	1494	172	2294	222	2809	272	3138	322	3337
		73	746	123	1511	173	2307	223	2817	273	3143	323	3339
24	200	74	760	124	1528	174	2320	224	2825	274	3148	324	3342
25	208	75	773	125	1546	175	2332	225	2833	275	3153	325	3345
26	217	76	786	126	1563	176	2345	226	2841	276	3158	326	3347
27	225	77	800	127	1580	177	2357	227	2849	277	3163	327	3350
28	233	78	814	128	1598	178	2369	228	2857	278	3167	328	3353
29	242	79	828	129	1615	179	2381	229	2865	279	3172	329	3355
30	250	80	841	130	1632	180	2393	230	2872	280	3176	330	3358
31	258	81	855	131	1650	181	2405	231	2880	281	3181	331	3361
32	267	82	869	132	1667	182	2416	232	2888	282	3185	332	3363
33	275	83	883	133	1684	183	2428	233	2895	283	3189	333	3366
34	283	84	897	134	1702	184	2440	234	2903	284	3194	334	3368
35	292	85	911	135	1719	185	2451	235	2910	285	3198	335	3371
36	300	86	926	136	1736	186	2463	236	2918	286	3202	336	3373
37	308	87	940	137	1753	187	2474	237	2925	287	3207	337	3375
38	316	88	955	138	1770	188	2486	238	2932	288	3211	338	3378
39	325	89	969	139	1787	189	2497	239	2939	289	3215	339	3380
40	334	90	984	140	1803	190	2508	240	2946	290	3220	340	3382
41	344	91	999	141	1820	191	2519	241	2953	291	3224	341	3385
42	354	92	1014	142	1837	192	2530	242	2959	292	3228	342	3387
43	364	93	1029	143	1853	193	2541	243	2966	293	3233	343	3389
44	374	94	1044	144	1870	194	2552	244	2973	294	3237	344	3392
45	385	95	1059	145	1886	195	2562	245	2979	295	3241	345	3394
46	396	96	1074	146	1903	196	2572	246	2986	296	3246	346	3396
47	408	97	1089	147	1919	197	2582	247	2993	297	3250	347	3399
48	420	98	1105	148	1935	198	2592	248	3000	298	3254	348	3401
49	432	99	1120	149	1952	199	2602	249	3006	299	3258	349	3403
50	443	100	1135	150	1968	200	2612	250	3012	300	3262	350	3406
51	455	101	1151	151	1984	201	2622	251	3018	301	3266	351	3408
52	467	102	1166	152	2000	202	2632	252	3024	302	3270	352	3410
53	478	103	1181	153	2016	203	2641	253	3030	303	3274	353	3412
54	490	104	1196	154	2032	204	2650	254	3036	304	3278	354	3414
55	503	105	1212	155	2049	205	2659	255	3042	305	3281	355	3416
56	516	106	1228	156	2064	206	2669	256	3048	306	3285	356	3418
57	530	107	1244	157	2080	207	2678	257	3054	307	3288	357	3420
58	544	108	1260	158	2096	208	2687	258	3060	308	3292	358	3422
59	559	109	1276	159	2111	209	2996	259	3066	309	3295	359	3423
60	573	110	1293	160	2126	210	2705	260	3072	310	3298	360	3425
61	587	111	1309	161	2141	211	2714	261	3078	311	3302	361	3427
62	600	112	1326	162	2155	212	2723	262	3084	312	3305	362	3428
63	613	113	1342	163	2169	213	2732	263	3089	313	3308	363	3430
64	626	114	1359	164	2184	214	2741	264	3095	314	3312	364	3432
65	639	115	1376	165	2198	215	2749	265	3101	315	3315	365	3433
66	653	116	1392	166	2212	216	2758	266	3106	316	3318		
67	666	117	1409	167	2226	217	2767	267	3112	317	3322		
68	680	118	1426	168	2240	218	2775	268	3117	318	3325		
69	693	119	1442	169	2254	219	2784	269	3123	319	3328		
70	706	120	1459	170	2268	220	2792	270	3128	320	3331		

Note: Freeboard at intermediate lengths of vessel shall be obtained by linear interpolation. Vessels above 365 metres in length shall be dealt with by the Authority.

Length in metres and Freeboard in millimeters.

APPENDIX C TABULAR FREEBOARD FOR TYPE B VESSELS

<i>Length</i>	<i>Freeboard</i>	<i>Length</i>	<i>Freeboard</i>	<i>Length</i>	<i>Freeboard</i>	<i>Length</i>	<i>Freeboard</i>	<i>Length</i>	<i>Freeboard</i>	<i>Length</i>	<i>Freeboard</i>	<i>Length</i>	<i>Freeboard</i>
		71	738	121	1709	171	2735	221	3601	271	4289	321	4855
		72	754	122	1729	172	2754	222	3615	272	4302	322	4866
		73	769	123	1750	173	2774	223	3630	273	4315	323	4878
24	200	74	784	124	1771	174	2795	224	3645	274	4327	324	4890
25	208	75	800	125	1793	175	2815	225	3660	275	4339	325	4899
26	217	76	816	126	1815	176	2835	226	3675	276	4350	326	4909
27	225	77	833	127	1837	177	2855	227	3690	277	4362	327	4920
28	233	78	850	128	1859	178	2875	228	3705	278	4373	328	4931
29	242	79	868	129	1880	179	2895	229	3720	279	4385	329	4943
30	250	80	887	130	1901	180	2915	230	3735	280	4397	330	4955
31	258	81	905	131	1921	181	2933	231	3750	281	4408	331	4965
32	267	82	923	132	1940	182	2952	232	3765	282	4420	332	4975
33	275	83	942	133	1959	183	2970	233	3780	283	4432	333	4985
34	283	84	960	134	1979	184	2988	234	3795	284	4443	334	4995
35	292	85	978	135	2000	185	3007	235	3808	285	4455	335	5005
36	300	86	996	136	2021	186	3025	236	3821	286	4467	336	5015
37	308	87	1015	137	2043	187	3044	237	3835	287	4478	337	5025
38	316	88	1034	138	2065	188	3062	238	3849	288	4490	338	5035
39	325	89	1054	139	2087	189	3080	239	3864	289	4502	339	5045
40	334	90	1075	140	2109	190	3098	240	3880	290	4513	340	5055
41	344	91	1096	141	2130	191	3116	241	3893	291	4525	341	5065
42	354	92	1116	142	2151	192	3134	242	3906	292	4537	342	5075
43	364	93	1135	143	2171	193	3151	243	3920	293	4548	343	5086
44	374	94	1154	144	2190	194	3167	244	3934	294	4560	344	5097
45	385	95	1172	145	2209	195	3185	245	3949	295	4572	345	5108
46	396	96	1190	146	2229	196	3202	246	3965	296	4583	346	5119
47	408	97	1209	147	2250	197	3219	247	3978	297	4595	347	5130
48	420	98	1229	148	2271	198	3235	248	3992	298	4607	348	5140
49	432	99	1250	149	2293	199	3249	249	4005	299	4618	349	5150
50	443	100	1271	150	2315	200	3264	250	4018	300	4630	350	5160
51	455	101	1293	151	2334	201	3280	251	4032	301	4642	351	5170
52	467	102	1315	152	2354	202	3296	252	4045	302	4654	352	5180
53	478	103	1337	153	2375	203	3313	253	4058	303	4665	353	5190
54	490	104	1359	154	2396	204	3330	254	4072	304	4676	354	5200
55	503	105	1380	155	2418	205	3347	255	4085	305	4686	355	5210
56	516	106	1401	156	2440	206	3363	256	4098	306	4695	356	5220
57	530	107	1421	157	2460	207	3380	257	4112	307	4704	357	5230
58	544	108	1440	158	2480	208	3397	258	4125	308	4714	358	5240
59	559	109	1459	159	2500	209	3413	259	4139	309	4725	359	5250
60	573	110	1479	160	2520	210	3430	260	4152	310	4736	360	5260
61	587	III	1500	161	2540	211	3445	261	4165	311	4748	361	5268
62	601	112	1521	162	2560	212	3460	262	4177	312	4757	362	5276
63	615	113	1543	163	2580	213	3475	263	4189	313	4768	363	5285
64	629	114	1565	164	2600	214	3490	264	4201	314	4779	364	5294
65	644	115	1587	165	2620	215	3505	265	4214	315	4790	365	5303
66	659	116	1609	166	2640	216	3520	266	4227	316	4801		
67	674	117	1630	167	2660	217	3537	267	4240	317	4812		
68	689	118	1651	168	2680	218	3554	268	4252	318	4823		
69	705	119	1671	169	2698	219	3570	269	4264	319	4834		
70	721	120	1690	170	2716	220	3586	270	4276	320	4844		

Note: Freeboard at intermediate lengths of vessel shall be obtained by linear interpolation. Vessels above 365 metres in length shall be dealt with by the Authority.

Length in metres and Freeboard in millimeters.

APPENDIX D PROVISIONS FOR DETERMINATION OF APPROPRIATE LOAD LINES - CLAUSE 68

This Schedule contains those Zones, Seasonal Zones and Areas, the respective Seasonal Periods of such Zones, for the determination of appropriate Load Lines to which vessels are permitted to load.

The following Zones and Areas are contained within the following limits

Latitude 00° 00' to Latitude 55° 00' S

Longitude 98° 00' E to Longitude 170° 00' E

and include Australia and those adjacent islands under State jurisdiction.

Tropical Zone Area 1 (Northern Australia)

For the purpose of this Section, the Tropical Zone shall be within those waters that lie to the southward of the Equator and to the northward of a thumb line drawn from a position latitude 10° 00' S longitude 98° 00' E to Port Darwin, thence along the north coast of Australia and the coast of Wessel Island eastwards to Cape Wessel, thence along the parallel of latitude 11° 00' S to the west side of Cape York and from the East side of Cape York along the parallel of latitude 11° 00' S to longitude 170° 00' E.

Tropical Zone Area 2 (Great Barrier Reef)

This area shall be bounded in the south by the parallel of latitude 22° 00' S, from the east coast of Australia to the Great Barrier Reef, then northwards along the Great Barrier Reef to latitude 11° 00' S and thence along that parallel to the east side of Cape York, Australia.

Seasonal Tropical Zone

For the purposes of this Section, the Seasonal Tropical Zone shall be divided into three areas -

Area 1 - South Indian Ocean Seasonal Tropical Area:

This area shall be bounded in the south from longitude 98° 00' E along the parallel of latitude 15° 00' S to longitude 114° 00' E and thence southward along the meridian of longitude of 114° 00' to the coast of North-west Australia, thence north-eastward along the coast of Australia to Port Darwin and thence along a rhumb line drawn from Port Darwin to position latitude 10° 00' S longitude 98° 00' E.

(Amendment dated March 1996)

The Seasonal Tropical period for this area will commence on the first day of May in a year and end on the thirtieth day of November in that year.

The Seasonal Summer period for this area will commence on the first day of December in one year and end on the thirtieth day of April in the following year.

Area 2 - South Pacific Ocean Seasonal Tropical Area (Gulf of Carpentaria):

This area shall be within that part of the Gulf of Carpentaria that lies south of latitude 11° 00' S.

The Seasonal Tropical period for this area will commence on the first day of April in a year and end on the thirtieth day of November the same year.

The Seasonal Summer period for this area will commence on the first day of December in one year and end on the thirty-first day of March the following year.

Area 3 - South Pacific Ocean Seasonal Tropical Area (East of Great Barrier Reef):

This area shall be bounded in the north and east by the southern boundary of the Tropical Zone (11° 00' S), to longitude 170° 00' E, thence in the south along the Tropic of Capricorn (23° 30' S) to longitude 154° 00' E, then southward to 24° 00' S, thence westward to the east coast of Australia, thence northward along the east coast of Australia, to latitude 22° 00' S, thence eastwards to the Great Barrier Reef and northwards along the Great Barrier Reef until it joins the Tropical Zone at 11° 00' S.

The Seasonal Tropical period for this area will commence on the first day of April in a year and end on the thirtieth day of November in that year.

The Seasonal Summer period for this area will commence on the first day of December in one year and end on thirty-first day of March in the following year.

(Amendment dated March 1996)

Southern Winter Seasonal Zone

This area shall lie to the southward of a line drawn from position latitude 35° 10' S, longitude 98° 00' E to a position at latitude 35° 30' S, longitude 118° 00' E, thence along a rhumb line to Cape Grim on the north-west coast of Tasmania, thence along the north and east coasts of Tasmania to the southernmost

point of Bruny Island, thence along a rhumb line to Black Rock Point on Stewart Island, New Zealand, thence along the rhumb line to the point latitude 47° 00'S, longitude 170° 00' E.

The Seasonal Southern Winter Period will commence on the sixteenth day of April in a year and end on the fifteenth day of October of that year.

The summer period of the Southern Winter Seasonal Zone will commence on the sixteenth day of October of a year and end on the fifteenth day of April the following year.

Summer Zone

The Summer Zone is the area that lies to the southward of the Seasonal Tropical Zones as defined, and to the northward of the Southern Winter Seasonal Zone as defined and between the longitudes 98° 00' E and 170° 00' E.

Note: the following chart should be amended to accord with the above described zones.

(Amendment dated March 1996)

Load Lines

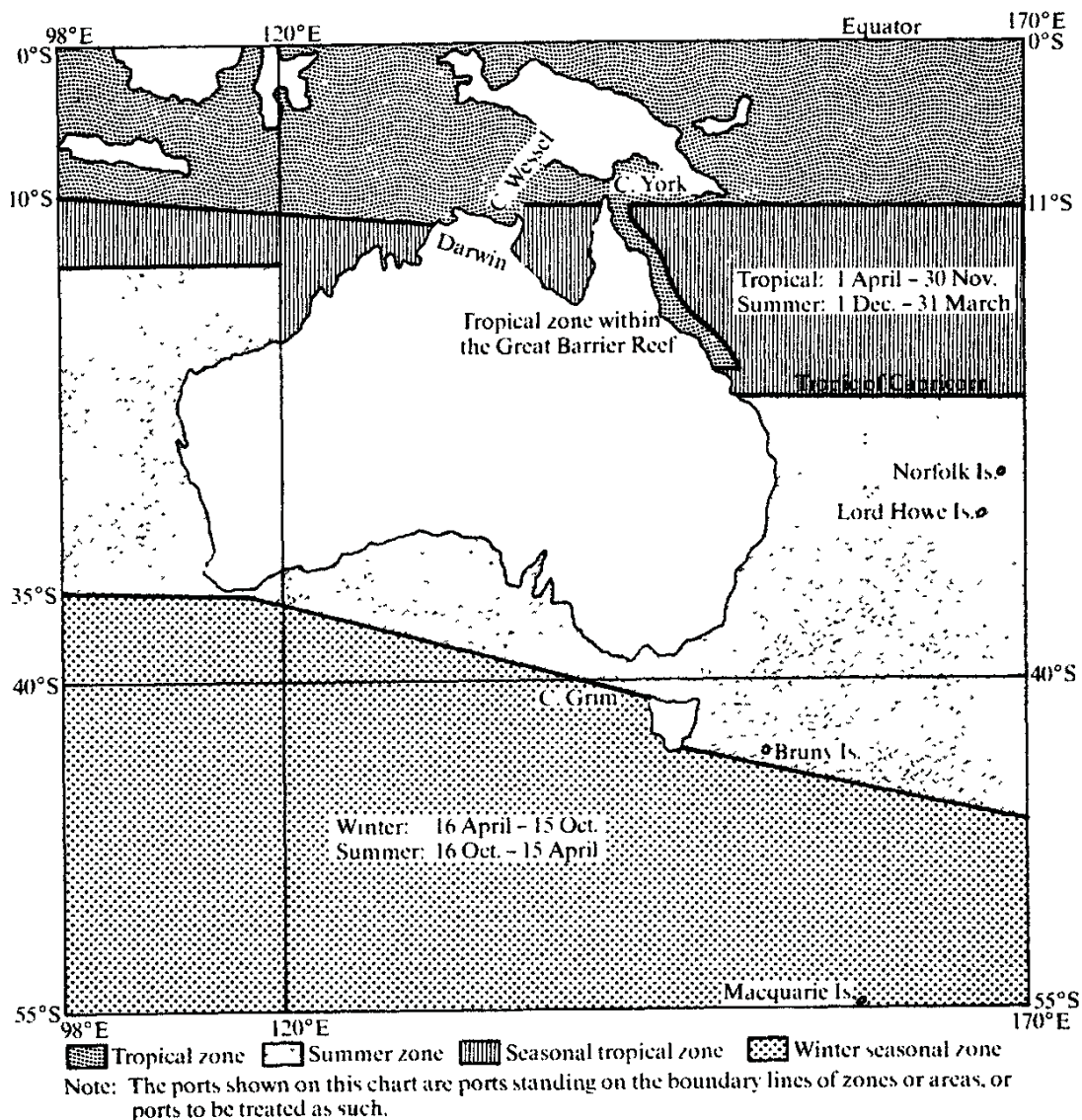

Zones Areas and Seasonal Periods

APPENDIX E

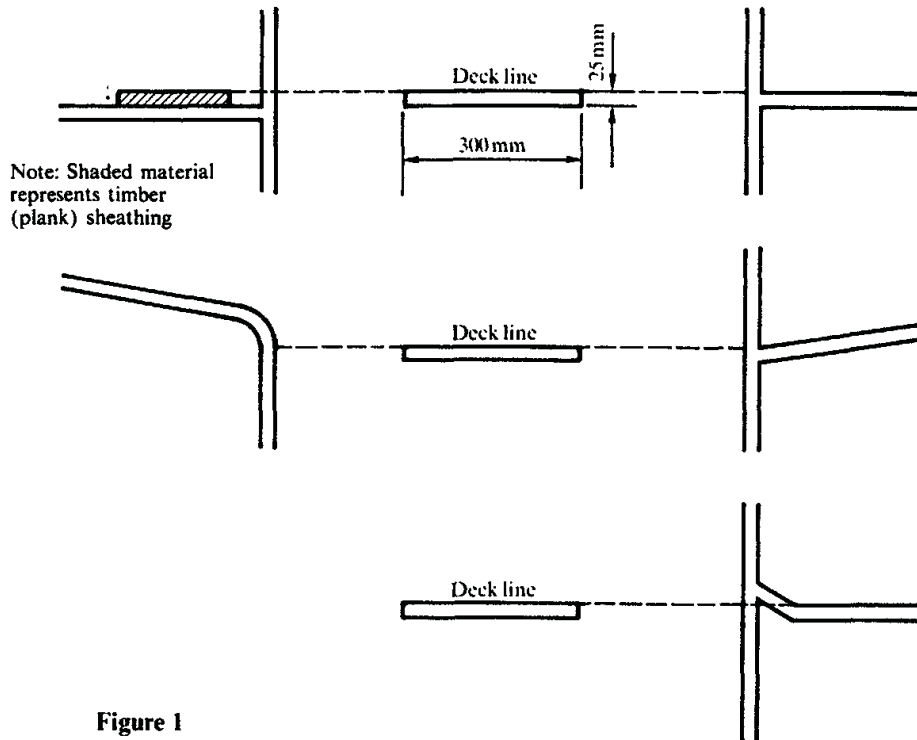

Figure 1

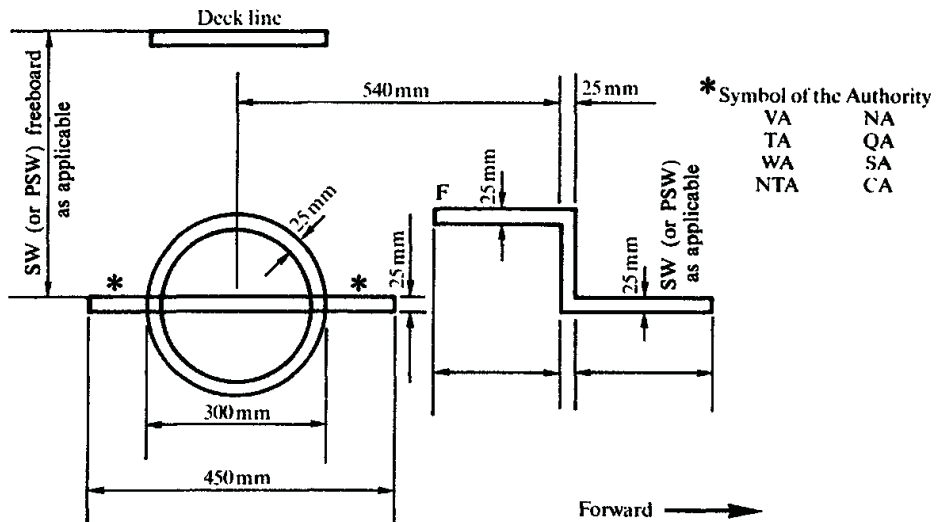

Figure 2

**LOAD LINE MARKINGS
SMOOTH AND PARTIALLY SMOOTH WATERS**

APPENDIX F

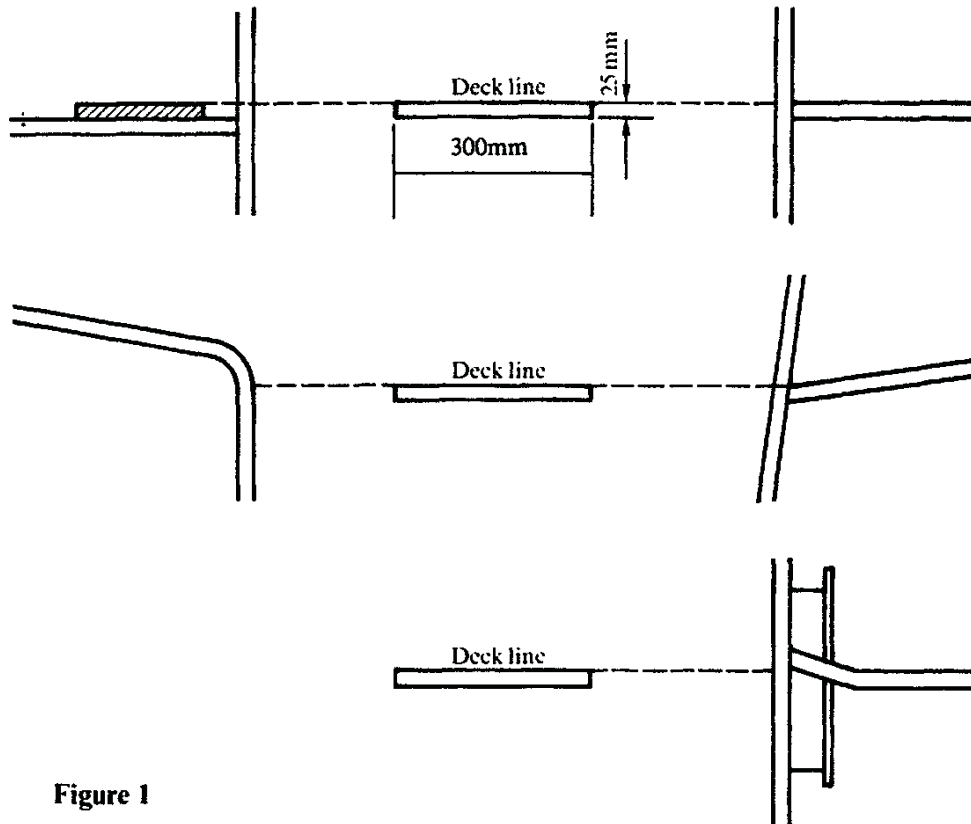

Figure 1

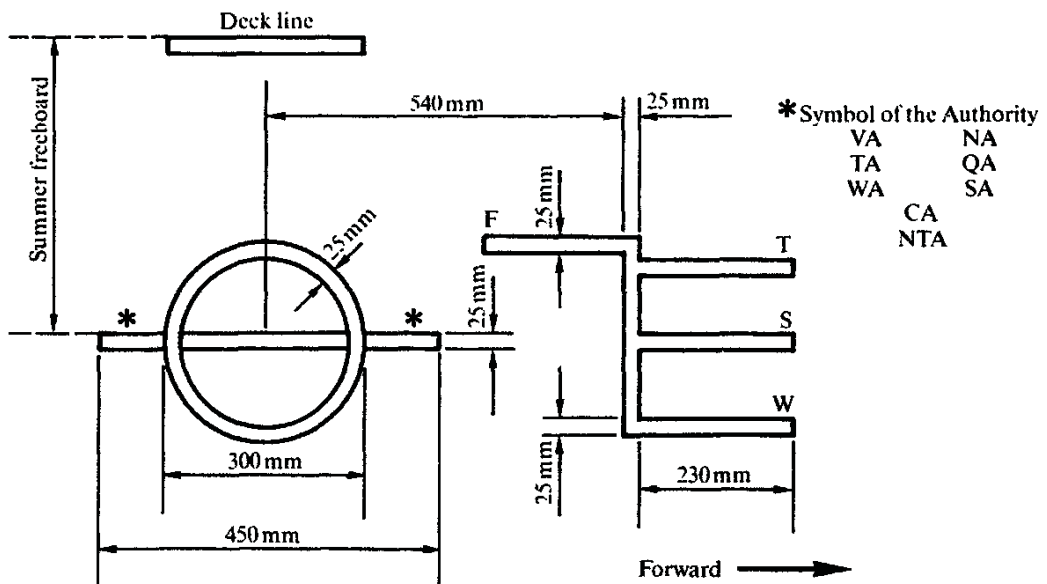

Figure 2

APPENDIX G

No.....

**Assigning Authority
LOAD LINE CERTIFICATE**

Issued under the provisions of the Act under the Authority of the
Government of by (Survey Authority)

Name of Vessel	Distinctive Number or Letters	Port of Registry	Length (L) as defined in Clause 3
----------------	-------------------------------	------------------	-----------------------------------

* Freeboard assigned as: A new vessel, An existing vessel. Type of Vessel: Type A, Type B with reduced/increased freeboard, PSW, SW

Freeboard for Deck Line	Load Line
Tropical mm	(T)..... mm above (S)
Summer mm	(S) Upper edge through centre of ring
Winter..... mm	(W) mm below (S)

Allowance for fresh water mm.

The upper edge of the deck from which these freeboards are measured is..... deck at side.

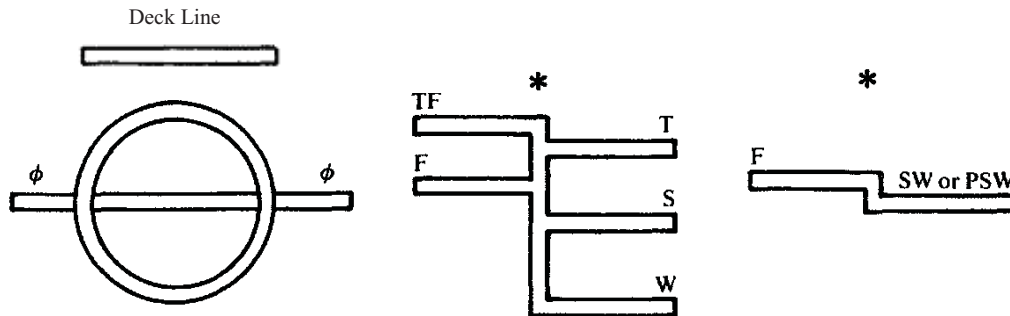

Date of Survey

Restrictions applicable to vessel.....
.....
.....

Φ Authorities Symbols QA NA VA TA SA WA CA NTA

* Delete as appropriate

This is to certify that this vessel has been surveyed and the freeboards and load lines shown above have been assigned in accordance with the Load Lines Section of the Recommended Uniform Requirements. This certificate is valid until subject to periodical inspection in accordance with that Section. Issued at..... on..... 20.....

The undersigned declares that
is authorised by the to issue this certificate.

APPENDIX H

No.....

**Load Line
EXEMPTION CERTIFICATE**

Issued under the provisions of the Act under the Authority of the
Government of by (Survey Authority)

Name of Vessel	Distinctive Number or Letters	Port of Registry
----------------	-------------------------------	------------------

This is to certify that the above-mentioned vessel is exempted pursuant to clause 73 of the Load Lines Section of the Recommended Uniform Requirements from

- * The provisions of sub-clause 73.1 of the Load Lines Section of the Recommended Uniform Requirements.
- * The provisions of the following clauses of the Load Lines Section of the Recommended Uniform Requirements:
.....
.....
.....

† Subject to the following conditions:
.....
.....
.....

* Delete whichever is inapplicable

† Delete if inapplicable

This certificate is valid until subject to periodical inspection in accordance with that Section.
Issued at..... on..... 20.....