

Uniform Shipping Laws Code 2008

**Section 8A: Stability - Preliminary
(CTH, NSW, NT, QLD, SA, TAS, VIC & WA)**

This is not the official version of the Uniform Shipping Laws Code.
The official version is that last published by the Australian Government Publishing Service,
Canberra, copies of which can be obtained from the National Marine Safety Committee.

SUB-SECTION A

Preliminary

This section is divided into Parts, as follows:

- A.1 General
 - A.2 Application
 - A.3 Conduct of Inclining Experiments and Position of Draught Marks
 - A.4 Presentation of Data
- Appendix A – Specification for Carrying Out and Reporting on Inclining Experiments and Lightship Measurements
- Appendix B – Specification for Positioning and Marking of Draught Marks

A.1 General

This Section shall be read in conjunction with the Introduction, Definitions and General Requirements Section.

A.2 Application

A.2.1 This Section applies to every vessel subject to the survey of an Authority. Where difficulty is experienced in respect of a particular vessel's meeting these Requirements, the matter should be referred to the Authority for decision. Where alterations are made to an existing vessel, such as materially to affect the stability of the vessel, the Authority may require the vessel to be re-inclined and a re-assessment made as to the ability of the vessel to meet the applicable criteria.

A.2.2 Vessels less than 7.5 m in measured length. Notwithstanding that Class 1D, 1E, 2D, 2E or hire and drive vessels of less than 7.5 m in measured length may be required to comply with this Section, the maximum person capacity for such vessels shall be determined in accordance with the S.A.A. Small Boat Code.

A.3 Conduct of Inclining Experiments and Position of Draught Marks

The methods to be employed in carrying out and reporting on inclining experiments are to be in accordance with Appendix A. Draught marks are to be positioned and marked in accordance with Appendix B.

A.4 Presentation of Data

A.4.1 The information relating to the stability of a vessel other than a vessel to which clause B.2 of the Stability Section applies, which is to be provided for the Master pursuant to clauses 4 and 25 of the Load Lines Section shall include particulars appropriate to the vessel of the matters specified below. Such particulars shall be in the form of a statement unless the contrary is indicated.

A.4.1.1 The vessel's name, official number, port of registry, gross and register tonnages, principal dimensions, displacement, deadweight and draught to the Summer load line.

A.4.1.2 A profile view and, if the Authority requires in a particular case, plan views of the vessel drawn to scale showing with their names all compartments, tanks, storerooms and crew and passenger accommodation spaces, and also showing the mid-length position.

A.4.1.3 The capacity and the centre of gravity (longitudinally and vertically) of every compartment available for the carriage of cargo, fuel, stores, feed water, domestic water or water ballast.

In the case of a vehicle ferry, the vertical centre of gravity of compartments for the carriage of vehicles shall be based on the estimated centres of gravity of the vehicles and not on the volumetric centres of the compartments.

A.4.1.4 Tank calibrations for every tank having a capacity of 2 tonnes or over. In the case of a tank, e.g. a ballast tank which will be kept full in service, the Authority may permit calibrations to be dispensed with.

- A.4.1.5 The estimated total mass of (a) passengers and their effects and (b) crew and their effects, and the centre of gravity (longitudinally and vertically) of each such total mass. In assessing such centres of gravity passengers and crew shall be assumed to be distributed about the vessel in the spaces they will normally occupy including the highest decks to which either or both have access.
- A.4.1.6 The estimated mass and the disposition and centre of gravity of the maximum amount of deck cargo which the vessel may reasonably be expected to carry on an exposed deck. The estimated mass shall include in the case of deck cargo likely to absorb water the estimated mass of water likely to be absorbed and allowed for in arrival conditions, such mass in the case of timber deck cargo being taken to be 15 per cent by mass.
- A.4.1.7 A diagram to scale showing the load line mark and load lines with particulars of the corresponding freeboards, and also showing the displacement, tonnes per centimetre immersion, and deadweight corresponding in each case to a range of mean draughts extending between the waterline representing the deepest load line and the waterline of the vessel in light condition.
- A.4.1.8 A diagram or tabular statement showing the hydrostatic particulars of the vessel, including:
- (a) displacement (extreme) in fresh water;
 - (b) displacement (extreme) in salt water;
 - (c) transverse metacentre above keel;
 - (d) tonnes per centimetre immersion;
 - (e) moment (tonne metres) to change trim one centimetre;
 - (f) longitudinal centre of buoyancy; and
 - (g) longitudinal centre of flotation,
- for a range of mean draughts extending at least between the waterline representing the deepest load line and the waterline of the vessel in light condition. Where a tabular statement is used, the intervals between such draughts shall be sufficiently close to permit accurate interpolation. In the case of a vessel having a raked keel, the same datum for the heights of centres of buoyancy and metacentre shall be used as for the centres of gravity referred to in A.4.1.3, A.4.1.5 and A.4.1.6.
- A.4.1.9 The effect on stability of free surface in each tank in the vessel in which liquids may be carried, and in which the free surface effect has a significant effect on the stability of the vessel. An example should be included to show how the metacentric height is to be corrected.
- A.4.1.10
- (1) A diagram showing cross curves of stability, calculated by the free-trimming method, at 10° intervals of heel based on an assumed axis at the intersection of the centre line and the base line amidships from which the righting levers are measured.
 - (2) Where during operations, the trim of a vessel is likely to exceed the limits laid down in subparagraphs 7.1 and 7.2 of Appendix A, then trimmed GZ curves shall be provided for not less than 2 trimmed conditions in addition to the even keel condition, where required by the Authority.
 - (3) Subject to the following sub-paragraph, only:
 - (a) enclosed superstructures; and
 - (b) efficient trunks,
 shall be taken into account in deriving such curves.
 - (4) The following structures may be taken into account in deriving such curves if the Authority is satisfied that their location, integrity, and means of closure will contribute to the vessel's stability:
 - (a) superstructures located above the superstructure deck;
 - (b) deckhouses on the freeboard deck which:
 - (i) comply with the conditions for enclosed superstructures laid down in the Load Lines Section;
 - (ii) have an additional exit to a deck above;

- (iii) have doors which comply with clause 6 of the Load Lines Section;
- (c) hatchway structures on or above the freeboard deck.

Additionally, in the case of a vessel carrying timber deck cargo, the volume of the timber deck cargo, or a part thereof may with the Authority's approval be taken into account in deriving a supplementary curve of stability appropriate to the vessel when carrying such cargo.

- (5) The following structures shall not be taken into account:
 - (i) deckhouses which do not comply with the requirements laid down in A.4.1.10 (4) (b);
 - (ii) deckhouses on decks above the freeboard deck.
- (6) The following deck openings may be regarded as closed:
 - (i) openings within deckhouses on decks above the freeboard deck;
 - (ii) openings within deckhouses on the freeboard deck which comply with the conditions for enclosed superstructures laid down in the Load Lines Section but which do not have an additional exit to a deck above, even where such openings are not provided with a means of closure; and
 - (iii) openings inside a deckhouse the doors of which do not comply with clause 6 of the Load Lines Section, where the means of closure of the deck openings complies with the requirements of clause 10, 11, 12, 15 or 16 of the Load Lines Section.
- (7) Superstructures and deckhouses not regarded as enclosed can, however, be taken into account in stability calculations up to the angle at which their openings are flooded. (At this angle the statical stability curve should show one or more steps, and in subsequent computations the flooded space should be considered non-existent).
- (8) Where the buoyancy of a superstructure is to be taken into account in the calculation of stability information to be supplied in the case of a vehicle ferry or similar vessel having bow doors, side doors, or stern doors, there shall be included in the stability information a specific statement that such doors must be secured weathertight before the vessel proceeds to sea and that the cross curves of stability are based upon the assumption that such doors have been so secured.
- (9) In cases where the vessel would sink due to flooding through any openings, the stability curve should be cut short at the corresponding angle of flooding and the vessel should be considered to have entirely lost its stability.
- (10) Small openings such as those for passing wires or chains, tackle and anchors, and also holes of scuppers, discharge and sanitary pipes should not be considered as open if they submerge at an angle of inclination more than 30°. If they submerge at an angle of 30° or less, these openings should be assumed open if the Authority considers this to be a source of significant flooding.
- (11) The calculations should take into account the volume to the upper surface of the deck sheathing. In the case of a timber vessel, the dimensions should be taken to the outside of the hull planking.
- (12) An example shall be given showing how to obtain a curve of Righting Levers (GZ) from the cross curves of stability.

A.4.1.11

- (1) The diagram and statements referred to in subparagraph (2) of this paragraph shall be provided separately for each of the following conditions of the vessel (except in the case of a dredger operating with hold spaces open, for which see A.4.1.15):
 - (a) Light conditions. If the vessel has permanent ballast, such diagram and statements shall be provided for the vessel in light conditions both (i) with such ballast, and (ii) without such ballast.
 - (b) Ballast Condition. Both (i) on departure, and (ii) on arrival, it being assumed for the purpose of the later in this and the following sub-paragraphs, that oil fuel,

fresh water, consumable stores and the like are reduced to 10 per cent of their capacity. In the departure condition all fuel and freshwater tanks shall be full with free surface allowed in at least one main fuel and freshwater tank, in each case using the maximum free surface numeral.

- (c) Homogeneous Loaded Condition. Condition both (i) on departure, and (ii) on arrival, when loaded to the Summer load line with cargo filling all spaces available for cargo. Cargo for this purpose is taken to be homogenous except where this is clearly inappropriate, for example where this is cargo spaces in a vessel which are intended to be used exclusively for the carriage of vehicles or of containers. The assumptions made in A.4.11.1 (b) shall also be made.
- (d) Service Loaded Conditions. Both (i) on departure and (ii) on arrival, the assumptions made in A.4.11.1 (b) being made.

(2)

- (a) A profile diagram of the vessel drawn to a suitable small scale showing the disposition of all components of the deadweight.
- (b) A statement showing the lightweight, the disposition and the total mass of all components of the deadweight, the displacement, the corresponding positions of the centre of gravity, the metacentre and also the metacentric height (GM).
- (c) A diagram showing a curve of Righting Levers (GZ) derived from the cross curves of stability referred to in A.4.1.10. Where credit is shown for the buoyancy of a timber deck cargo the curve of Righting Levers (GZ) must be drawn both with and without this credit.

- (3) The metacentric height and the curve of Righting Levers (GZ) shall be corrected for liquid free surface.
- (4) Where there is an amount of trim in any of the conditions referred to in sub-paragraph (1) which exceeds the limits laid down in sub-paragraphs 7.1 and 7.2 of Appendix A, the metacentric height and the curve of Righting Levers (GZ) may be required to be determined from the trimmed waterline.
- (5) If in the opinion of the Authority the stability characteristics in either or both of the conditions referred to in sub-paragraph (1) (c) are not satisfactory, such conditions shall be marked accordingly and an appropriate warning to the Master shall be inserted.

A.4.1.12 Where special procedures such as partly filling or completely filling particular spaces designated for cargo, fuel, fresh water or other purposes are necessary to maintain adequate stability, a statement of instructions as to the appropriate procedure in each case.

A.4.1.13 Where anti-rolling devices are installed in a vessel, information on their proper use shall be provided.

A.4.1.14 A copy of the report on the inclining test and of the calculation therefrom of the light condition particulars.

A.4.1.15 In the case of a dredger operating with holds open or a dredger operating with holds closed, the stability of the vessel shall be fully investigated and the following minimum number of conditions included in the data:

- (i) Lightship:
If the vessel is fitted with bottom doors, water should be assumed to be in the hold space.
- (ii) Arrival and departure conditions for the vessel loaded with:
 - (a) water ballast;
 - (b) cargo of the anticipated maximum density; and
 - (c) cargo of the anticipated minimum density.

Due to the large volume of water and the resultant free surface effect which exists in the early stages of loading a suction type dredger, a more onerous condition than when the vessel is fully loaded may then exist. The GZ curves for the final conditions of loading should therefore have superimposed upon them curves indicating the statical stability of the

vessel in the early stages of loading, i.e. when the hold contains only one third of the intended load of dredgings plus the relative quantity of water.

- (iii) In a vessel fitted with double bottom doors or other similar means of jettisoning cargo, a condition to indicate the heeling effect should the doors on one side fail to open when the vessel is in its worst condition as regards stability, e.g. as in A.4.1.15 (ii)(b) or A.4.1.15 (ii)(c) above.

A.4.1.16 For derrick barges, crane barges and heavy lift vessels operating in seagoing areas, information as to loading limitations (both on the derrick or jib and on the deck) and heel criteria shall be included in the stability book together with all necessary information as to hook load/lifting radius limits related to heel of the vessel.

A.4.1.17 Where counter ballasting is utilised, full instructions shall be included in the stability book covering amounts of ballast required for various heeling moments, together with the corresponding free surface effects.

In order to guard against serious deficiency in stability occasioned by sudden loss of load the following investigations should be made:

- (a) The excess righting arm area in metre degrees on the counterballast side of the vessel must be adequate to absorb the static energy put into the system by the sudden loss of the load and the action of the seaway, if any. This energy should be measured from the ballast equilibrium angle on the counterballast side due to the heeling moment of the counterballast to the combined equilibrium angle on the load side of the barge. (See figure 1).
- (b) The righting energy (to the left of the axis) is the area above the righting arm curve and below the counterballast moment curve up to the angle of down-flooding or the point at which positive stability is lost. In still water, the righting energy (Area II) must be greater than the heeling energy (Area I). In a seaway, the righting energy must be greater than the heeling energy plus 2.12 metre degrees.
- (c) The righting arm curve used to calculate the righting and heeling energy (see figure 1) is calculated at the draught and vertical centre of gravity of the barge without the load on the derrick or jib. The angle θ_L is determined from the intersection of the righting arm curve and (jib heel moment—counterballast moment) curve calculated for the barge with the load on the jib.
- (d) It should be noted that the righting arm curve will be discontinuous at the equilibrium angle (hook load side), since displacement and KG change with loss of hook load. (See figure 1).
- (e) Where counter ballasting arrangements are installed it should be noted that the problem involves four dimensions:
 - (i) draught;
 - (ii) maximum vertical moment;
 - (iii) jib or derrick radius; and
 - (iv) counterballast configuration.

If three radii are used, the number of tables to be provided is three times the number of counter ballasting configurations.

- (f) In the case of a barge with no counterballast but with a permanent counterweight, a table showing draught versus maximum vertical moment of deck cargo and hook load combined is required. This table is obtained by drawing righting arm curves for various KG values until the maximum KG which satisfies the criteria is obtained. This KG is then converted into a maximum vertical moment by subtracting the vertical moment due to the barge lightship.
- (g) With a permanent counterweight, the counter-heeling arm is defined at each displacement. The heeling arm is a variable depending on the maximum hook load capacity at each radius. The table may be made up only for the maximum heeling moment or for a range of moments. (Generally three radii will be found sufficient).

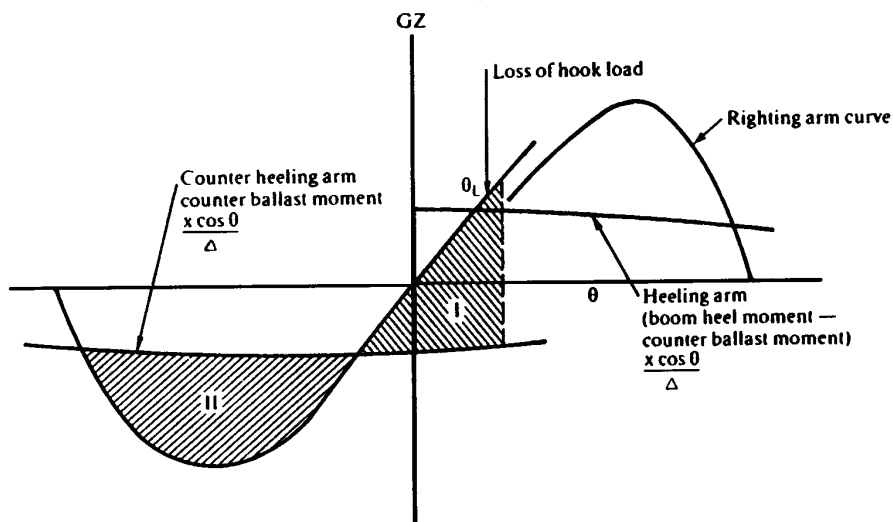

Figure 1

- (h) The righting arm analysis may be performed at only three displacements, viz.:
- (i) load displacement;
 - (ii) a displacement which will yield allowable vertical moments greater than ever expected to be necessary; and
 - (iii) an intermediate displacement.

The curve of allowable KG values against displacement will be approximately linear.

- (i) The procedure outlined above is based on the derrick or jib being a beam of the barge. It should be noted that heavier lifts and/or draughts are feasible for other boom configurations. Such lifts will be specially considered by the Authority.

A.4.1.18 In preparing a stability book for an offshore supply vessel or a vessel of similar configuration, the following points should be paid particular attention, in addition to those requirements expressed in earlier paragraphs of this sub-clause:

- (a) To assist the master in assessing the stability of his vessel in loading conditions differing from the standard ones, a curve or table giving, as a function of draught and trim, the required initial metacentric height (or other stability parameter) which ensures that the stability is in compliance with the criteria given in C.9.1 or C.9.2.;
- (b) Hydrostatic and stability curves should be prepared for the operating trim conditions taking into account the change in trim due to heel;
- (c) A minimum freeboard at the stern of at least $0.005L$ should be provided in all operating conditions; and
- (d) In addition to enclosed superstructures which comply with the requirements of the Load Lines Section, the second tier of similarly enclosed superstructures may also be taken into account.

A.4.1.19

- (i) The loading conditions of an off-shore supply vessel which should be examined are at least as follows:
- (a) Vessel in fully loaded departure condition with cargo distributed below deck and with cargo specified by position and weight on deck, with full stores and fuel, corresponding to the worst service condition in which all the relevant stability criteria are met.
 - (b) Same condition as in (a) but with 10 per cent stores and fuel.
 - (c) Vessel in ballast in the departure condition, without cargo but with full stores and fuel.

- (d) Vessel in ballast in the arrival condition, without cargo and with 10 per cent stores and fuel remaining.
- (e) Vessel in the worst anticipated operating condition.
- (ii) The assumptions to be made in calculating loading conditions are:
 - (a) For fully loaded conditions mentioned in (i) (a) and (b) above, if a vessel has tanks for liquid cargo, the effective deadweight in the loading conditions therein described should be distributed according to two assumptions, i.e. (1) cargo tanks full, and (2) cargo tanks empty.
 - (b) If in any loading condition water ballast is necessary, additional diagrams should be calculated taking into account the water ballast. Its quantity and disposition should be stated.
 - (c) In all cases when deck cargo is carried a realistic stowage weight should be assumed and stated, including the height of cargo and its centre of gravity.
 - (d) Where pipes are carried on deck, a quantity of trapped water equal to a certain percentage of the net volume of the pipe deck cargo should be assumed in and around the pipes. The net volume should be taken as the internal volume of the pipes plus the volume between the pipes. This percentage should be 30 per cent for a freeboard amidships equal to or less than 0.015 L and should be 10 per cent for a freeboard amidships equal to or greater than 0.03 L, where L is the length of the vessel as defined in sub-clause 3.16 of the Load Lines Section. For intermediate values of freeboard amidships the percentage may be obtained by linear interpolation. In assessing the quantity of trapped water, the Authority may take into account positive or negative sheer aft, actual trim and area of operation.

A.4.1.20 The conditions to be presented for tugs should include:

- (a) Lightship;
- (b) Service conditions with full, half full and 10 per cent loadings of fuel, fresh water and consumable stores; and
- (c) The effect of the tow rope heeling lever curve described in clause C.10.

A.4.1.21 The following guidance instructions should be incorporated in a tug's stability book:

- (a) When engaged in towing, large external heeling moments may be applied to the tug especially if the tow lead forms a large angle with the horizontal axis of the tug. Such a condition would be further aggravated in adverse conditions of weather and tide or if the ship under tow ran aground.
- (b) At the commencement of a tow it is important to ensure that the load placed upon the tow line and hook is applied gradually, particular regard being taken of the relative thrust of the tug and the resistance of the tow.
- (c) The combined effect of paragraphs (a) and (b) could produce an extremely dangerous condition and might eventually result in the tug capsizing if the angle of tow resulted in the production of an excessive transverse heeling moment.

A.4.1.22 For sailing vessels and auxiliaries in addition to the documents required by this clause, cross curves of stability to at least 90° should be provided. A curve of righting levers for the most severe operating condition from a stability viewpoint should be prepared.

A.4.1.23 Stability information to be carried onboard a vessel to which clause C.3 or clause C.4 applies, as prescribed by sub-clause 4.2 and clause 25 of the Load Lines Section shall take the form of guidance notes for the Master. In addition to the recommendations as to distribution of the cargo, fuel, water and stores, the notes shall contain:

- (a) Basic hydrostatic curves;
- (b) Rolling Period Factor F_r ;
- (c) GM (Min.) as calculated in the sub-clause C.3.2, or as determined in accordance with sub-clause C.4.2;

- (d) GM (Actual) for the conditions of loading calculated in sub-clause C.3.2, where appropriate; and
 - (e) A description of means of obtaining the vessel's GM using a rolling period test.
- A.4.2 Vessels not subject to the Load Lines Section are to have data consistent with the criteria for the appropriate type of vessel.
- A.4.2. In particular, Class 3 vessels, especially categories K and L (refer clause C.5), should be provided with guidance notes for the Master. In addition to recommendations as to the distribution of cargo, fuel, water and stores and gear loads, a statement setting out the method of operation and sequence of loading on a typical voyage should be included by the owner.
- A.5 Additional Requirements for Passenger Ships**
- A.5.1 At periodical intervals not exceeding five years, a lightweight survey shall be carried out on all passenger ships to verify any changes in lightship displacement and longitudinal centre of gravity. The ship be re-inclined whenever, in comparison with the approved stability information, a deviation from the lightship displacement exceeding 2% or a deviation of the longitudinal centre of gravity exceeding 1% of length is found, or anticipated.
- A.5.2 In addition to the requirements of A.4, the vessel's stability data shall include information which indicates the maximum permissible height of the ship's centre of gravity above keel (KG), or alternatively the minimum permissible metacentric height (GM), taking into account both intact and damage stability criteria, for a range of draughts or displacements sufficient to include all service conditions. The information shall show the influence of various trims taking into account the operational limits.
- A.5.3 In the case where the draught marks are not located where they are easily readable, or operational constraints for a particular trade make it difficult to read the draught marks, then the ship shall also be fitted with a reliable draught indicating system by which the bow and stern draughts can be determined.

APPENDIX A

**SPECIFICATION FOR CARRYING OUT AND REPORTING ON
INCLINING EXPERIMENTS AND LIGHTSHIP
MEASUREMENTS**

INDEX

<i>Paragraph</i>	<i>Subject</i>
1.	Introduction
2.	Dispensation from Carrying Out an Inclining Experiment
3.	Before the Inclining Experiment is to be Carried Out
4.	Control of the Work Force by the Person in Charge of the Experiment
5.	Items to be Checked at the Beginning of the Experiment
6.	The Inclining Experiment
7.	Calculation of the Displacement, LCB and KM_0 at Inclining
8.	Calculation of the VCG at Inclining
9.	Calculation of the LCG at Inclining
10.	Calculation of the Lightship Particulars
11.	Inclining Experiment Report
12.	The Lightship Measurement

This specification sets out the requirements for carrying out Inclining Experiments and Lightship Measurements when performed on vessels requiring to have their stability data approved by the Authority to comply with clause 4 of the Load Lines Section and the reporting of the results.

1. Introduction

- 1.1 The object of the Inclining Experiment is to obtain for the vessel the lightship displacement, the position of the vertical centre of gravity (VCG), and the position of the longitudinal centre of gravity (LCG). These lightship characteristics are the bases of every loading condition for the vessel.
- 1.2 The object of the Lightship Measurement is to obtain for the vessel the lightship displacement and the position of the longitudinal centre of gravity (LCG). These lightship characteristics are then compared with the lightship characteristics of the sister vessel which has already been inclined, to confirm that the lightship characteristics of the sister vessel can be used as the bases of the loadings conditions of the subject vessel.
- 1.3 The following matters which concern the accuracy of the Inclining Experiment/Lightship Measurement are to be considered when the Experiment/Measurement is being planned:
- 1.3.1 Every care must be taken at every stage of the Inclining Experiment and Lightship Measurement to achieve the highest possible accuracy.
- 1.3.2 The ship must be as near completion as can be arranged so that the total of the 'items on' and 'items off' are as small as possible. These items cannot be assessed as accurately as other factors of the Experiment.
- 1.3.3 In most cases the larger part of the 'items off' will be liquids. It is necessary to keep the total of these to an absolute minimum.
- 1.3.4 It has been demonstrated on several occasions that 'U' tubes tend to underestimate the heel of the vessel and hence to overestimate the GM_0 . Their use is not permitted.
- 1.3.5 The calculation of GM_0 at inclining depends on the waterplane of the vessel remaining substantially constant as the vessel is heeled. Many vessels now being built are of chine design with wide flat sterns. If the chines of such vessels are not immersed throughout the experiment, the waterplane varies dramatically as the vessel is heeled. All other abrupt changes of form are to be similarly considered.

- 1.4 If the desired standard of accuracy of the Experiment is not achieved, it will be necessary to repeat the Inclining Experiment or Lightship Measurement.
- 1.5 All readings and measurements taken during the Experiment or Measurement must be recorded in the units measured.
- 1.6 Approval may not be given to stability data based on any Experiment or Measurement which was not witnessed by a Surveyor.

(Amendment dated 16 June 1994)

2. Dispensation from carrying out an inclining experiment

- 2.1 Attention is drawn to the provision that a vessel which is built to the same lines plan and is in all respects similar in construction and outfit to an existing vessel which has approved stability data, may be eligible for dispensation from undergoing an Inclining Experiment.
- 2.2 Application for this dispensation shall be made in writing, and shall contain a detailed statement of all variations between the subject vessel and the sister vessel, in adequate time before completion of construction of the vessel.
- 2.3 If this dispensation is granted in writing, a Lightship Measurement must be carried out on the vessel in the presence of a Surveyor.

3. Before the inclining experiment is to be carried out

- 3.1 The date for carrying out the Inclining Experiment is to be set so that the vessel will be as near completion as can be arranged.
- 3.2 The draught marks are to have been verified by a Surveyor for accuracy, and compliance with the specification for Positioning and Marking of Draught Marks.
- 3.3 The basic information required for the Inclining Experiment calculations is to be gathered together so that it will be available on the vessel on the day of the Inclining Experiment. This information is to include:
 - 3.3.1 Hydrostatic Curves or a Hydrostatic Table;
 - 3.3.2 A Lines plan;
 - 3.3.3 Tank Calibration and Free Surface Information;
 - 3.3.4 An up-to-date General Arrangement plan; and
 - 3.3.5 Full details of the liquid transfer arrangements and measuring systems as accepted by the Authority when the vessel is to be heeled by the movement of liquid.
- 3.4 An estimate of the GM_o of the vessel at inclining is to be made so that the mass transfer moment to give a minimum of 2° and a maximum of 4° heel on either side of the upright can be calculated, the necessary masses obtained and their values verified.
 - 3.4.1 Four masses (or sets of masses) are required. Suitable arrangements are to be made for handling the masses across the deck of the vessel during the Inclining Experiment.
 - 3.4.2 Where the heeling moment required to achieve the necessary maximum heeling angle involves the movement of solid masses which are too large to handle, the heeling may be accomplished by the transfer of water. When this method is used, strict attention is to be paid to the following:
 - 3.4.2.1 The tanks must be fully calibrated over the full range of soundings to be used during the Experiment, so that the mass of the contents, the vertical and longitudinal centres of gravity of the contents and the free surface moments can be accurately established taking account of the trim and heel of the vessel at inclining. The calculations required are reduced and the accuracy of the results is greater if rectangular tanks are used.
 - 3.4.2.2 The method used for transferring liquid from one tank to the other must be simple, direct, reasonably quick, and involve the minimum possible leakage.
 - 3.4.2.3 A calibrated sight board is to be set up in each tank to measure the liquid level. Safe access and adequate lighting of the sight boards must be provided to permit accurate liquid level readings to be taken. The work of calculation is reduced and the accuracy increased if the sight boards are placed at the intersection of the longitudinal and transverse centres of the liquid surfaces. In a rectangular tank the sight board position would then be on the vertical axis of the tank.

- 3.4.2.4 Complete details of the proposed liquid transfer and recording systems are to be submitted to the Authority for examination and acceptance well in advance of the Inclining Experiment.
- 3.5 Vessels with high GM_0 values require very large inclining masses. Under certain circumstances, it might be agreed to accept a maximum angle of heel of less than 2° . If a review of the 2° requirement is desired, written application is to be made to the Authority. If suitable grounds are given, a lesser maximum angle of heel down to an absolute lower limit of 1° might be considered. If the application is approved, written confirmation will be given, and the nominated maximum heel angle to be achieved will be stated. The masses to be used must be adequate to heel the vessel to this angle.
- 3.6 The hydrometer, if it has not been checked within the last year, must be re-calibrated and a new certificate obtained.
- 3.7 Arrangements are to be made for the vessel to be berthed for the Experiment in a protected position where she will be afloat throughout the Experiment, and out of the effects of wind, tide and currents.
- 3.7.1 Arrangements are to be made for a boat which is suitable for use when reading the draught marks to be available during the Inclining Experiment.
- 3.8 Arrangements are to be made to meet the following tank content requirements during the Inclining Experiment:
- 3.8.1 The liquids on board must not exceed the amounts required to provide necessary services and essential ballasting;
- 3.8.2 Except with the express permission of the Authority, under no circumstances is the total mass of liquids on board to exceed 20 per cent of the lightship displacement; and
- 3.8.3 The liquids on board must be confined to the minimum number of tanks. If there are any spaces which contain small quantities of liquid, the Experiment should not proceed until these have been cleared.
- 3.9 When planning the ballasting of chine vessels with wide flat stems, which will include most tugs and oil rig supply vessels, landing barges, and the majority of modern fishing vessels, it is to be remembered that the chines aft are to remain immersed throughout the Inclining Experiment.
- 3.9.1 If, in special circumstances, the vessel cannot be trimmed sufficiently to keep the chines immersed with the permitted 20 per cent of the lightship mass of liquids on board, then solid masses of known value must be used in addition to the liquids, unless the express permission of the Authority has been obtained in accordance with 3.8.2.
- 3.9.2 In cases where the chine immersion is impractical, the Authority is to be notified in adequate time before the Inclining Experiment, so that a compromise procedure can be worked out for carrying out the experiment and performing the resulting calculations.
- 3.10 Two pendulums must be used for all vessels of 20 metres length and over. For vessels below that length the number of pendulums shall be at the discretion of the Authority. Positions for the pendulums are to be chosen:
- 3.10.1 Which are protected and remote from the ends of the vessel;
- 3.10.2 Where satisfactory effective pendulum lengths can be obtained;
- 3.10.3 Where suitable mountings for the marking strips can be provided; and
- 3.10.4 Where troughs of damping liquid can be provided for the pendulum bobs.

Note:

The pendulums are to be of markedly different effective lengths.

4. Control of the work force by the person in charge of the experiment

The person in charge of the Inclining Experiment must have control over the work force carrying out the Experiment. All other persons must be sent ashore and the gangway taken off for the duration of the Experiment.

5. Items to be checked at the beginning of the experiment

The following items are to be checked immediately before beginning the Inclining Experiment:

- 5.1 That the weather, wind, sea and tide conditions are suitable for the Inclining Experiment. The Experiment must not be conducted nor continued when it is raining.

- 5.2 That all persons not engaged in the Inclining Experiment are ashore and the gangway has been taken off.
- 5.3 That the person in charge of the Experiment has notified the person in charge of the engine room that the Inclining Experiment is beginning, and that no fluid handling of any kind is to take place throughout the Experiment.
- 5.4 That the person in charge of the Experiment has confirmed that:
 - 5.4.1 All engine room bilges are dry;
 - 5.4.2 All control valves for heeling and trimming tanks and cross-flooding connections have been securely closed; and
 - 5.4.3 All pumps not required for essential services have been shut down.
- 5.5 That movable masses, loose gear, shipyard plant and stagings, have, where practicable, been put ashore and those items which must remain on board have been secured against movement.
- 5.6 That the vessel is plumbed upright.
- 5.7 That all persons on board for the carrying out of the Experiment understand their duties and the positions they must take up while the pendulums are being read. Their masses and these positions are to be recorded for inclusion with the dry 'items off' in table 5.12.
- 5.8 That the vessel is afloat, that all moorings can be slacked off and the vessel easily kept clear of the wharf while the pendulum readings are being taken.
- 5.9 That all the inclining mass identifications have been confirmed against their weighbridge certificates, or equivalent.
- 5.10 That a sketch of the deck has been prepared which shows the initial positions of the inclining masses, and their positions after the movements. The mass movement distances are to be filled in as the Experiment proceeds.
- 5.11 That the pendulums are free to swing throughout the heeling of the vessel. The effective lengths of the pendulums are to be recorded.
- 5.12 The masses of all the 'items off' other than liquids are to be estimated, and the positions of their centres of gravity established with the aid of the general arrangement plan. All this information is to be recorded in a table similar to table 5.12.

6. The Inclining Experiment

- 6.1 All fresh water, fuel, lubricating oil, water ballast and cargo tanks are to be sounded and the readings recorded in a table similar to table 6.1.
- 6.2 The densities of the dock water at each end of the vessel and midships, on both sides of the vessel, are to be measured. Sufficient readings are to be taken to establish the average density, having regard to any 'layering' effect in the water.
- 6.3 The draught and where necessary, the freeboard readings forward, aft, and at midships on both sides of the vessel are to be taken.
- 6.4 Heeling the vessel:

The heeling of the vessel by the movement of the inclining masses is to be a continuous process and should not be interrupted. The time interval between the mass movements and the reading of the pendulums should be kept as constant as practicable.

Six mass movements are required viz.:

$\frac{1}{2}W$ Port to Starboard

$\frac{1}{2}W$ Port to Starboard

W Starboard to Port

$\frac{1}{2}W$ Starboard to Port

$\frac{1}{2}W$ Starboard to Port

W Port to Starboard

where W is the total of the masses placed on the one side of the vessel.

- 6.4.1 All members of the inclining party are to take up their positions for pendulum readings, and the zero positions of the pendulum are to be marked on the marking strips.
- 6.4.2 Make the first mass movement:
- 6.4.2.1 Measure and record the distance the mass has been moved;
- 6.4.2.2 If the vessel's gear is being used, re-stow the derrick and slacken the topping lift;
- 6.4.2.3 If shore gear is being used, uncouple the lifting hook;
- 6.4.2.4 Recall the inclining party members to their pendulum reading positions;
- 6.4.2.5 Make certain that all moorings are slack and that the vessel is clear of the berth;
- 6.4.2.6 When the pendulums are steady, record their positions on the marking strips and the time of the reading; and
- 6.4.2.7 Measure the distance of this pendulum position from the initial pendulum position, which is the pendulum deflection 'm', and determine the value of:
- $$\frac{w \times d}{m} = \frac{(\text{Heeling Moment})}{(\text{Pendulum Deflection})} \text{ for each pendulum;}$$
- 6.4.3 Repeat for each of the six mass movements required:
- 6.4.3.1 After calculating the pendulum deflections for each mass movement, calculate:
- $$\frac{(\text{Heeling Moment})}{(\text{Pendulum Deflection})} \text{ for each pendulum;}$$
- 6.4.3.2 Compare each successive:
- $$\frac{(\text{Heeling Moment})}{(\text{Pendulum Deflection})} \text{ value}$$
- with the average of the values calculated for the previous mass movements; and
- 6.4.3.3 If any value does not compare closely with the average of the previous values, re-check the following:
- 6.4.3.3.1 that the vessel is still clear of the berth and that the moorings are still slack;
- 6.4.3.3.2 the pendulum readings, making sure that the pendulums are free to swing;
- 6.4.3.3.3 the value of the mass last moved and the distance through which it was moved; and
- 6.4.3.3.4 that nothing aboard the vessel has moved due to heeling.
- If, after attention to the above, the value still does not compare closely, repeat the mass movement concerned.
- 6.4.4 After the set of six mass movements has been made, average the six values of:
- $$\frac{(\text{Heeling Moment})}{(\text{Pendulum Deflection})}$$
- 6.4.4.1 Compare the individual values of the:
- $$\frac{(\text{Heeling Moment})}{(\text{Pendulum Deflection})} \text{ with}$$
- the average value.
- 6.4.4.2 If an individual value varies from the average value by more than 5 per cent of the average value, then the corresponding mass movement must be repeated until a satisfactory set of values has been obtained.
- 6.4.5 If the following are observed, even after checking:
- 6.4.5.1 The pendulum zero checks are considerably erratic;
- 6.4.5.2 The pendulum deflections are greater than might have been expected;

6.4.5.3 There is an inconsistency in the values of the pendulum deflections for equal mass movements in opposite directions; and

6.4.5.4 The ship appears to have an unexplained initial list that cannot be corrected, then the vessel could be initially unstable, i.e. it could have a negative GM_0 value.

In this event the Inclining Experiment should be immediately discontinued, and contact made with the Authority, giving full details so that a satisfactory solution can be worked out.

6.4.6 The mass movements and pendulum deflections are to be recorded in a table similar to table 6.4.6.

6.4.7 Record the readings obtained during the Inclining Experiment, when using liquid transfer, in a table similar to table 6.4.7.

6.5 When preparing the table for liquid 'items off' similar to table 6.1, it is to be remembered that the soundings (or ullages) read for each tank are to be corrected for trim, using the tank calibration curves (or tables) provided. It is from the corrected sounding for each tank that the mass of the liquid content and its vertical and longitudinal centres of gravity are read off.

6.6 A table is to be drawn up similar to table 6.6 listing all items to be put on board to complete the lightship, with their masses and their vertical and longitudinal centres of gravity.

6.7 In cases where solid ballast is fitted, the masses and centres of gravity of the ballast in each stowage position are to be recorded.

7. Calculation of the displacement, LCB and KM_0 at inclining

7.1 If the vessel being inclined has reasonably similar shapes at bow and stern, such as is normal with bulk carriers, tankers, coasters, conventional cargo vessels, and many fishing vessels of the older style, then the hydrostatic curves can be used to determine the hydrostatic elements at inclining (i.e. displacement, LCB and KM_0) if the trim in metres does not exceed the following values:

$$\frac{L_{BP}}{50} \quad \text{for vessels of } L_{BP} \text{ of less than 35 metres;}$$

$$\frac{L_{BP}}{75} \quad \text{for vessels of } L_{BP} \text{ of 35 metres and over but less than 70 metres; and}$$

$$\frac{L_{BP}}{100} \quad \text{for vessels of } L_{BP} \text{ of 70 metres and over.}$$

7.2 If the vessel has a fine bow and a full flat stern as is usual with oil rig supply vessels, tugs, roll-on/roll-off vessels and many modern fishing vessels, then the hydrostatic curves can be used to determine the hydrostatic elements at inclining only if the trim in metres does not exceed the following values:

0.3 metres for vessels of L_{BP} of less than 45 metres; and

$$\frac{L_{BP}}{150} \quad \text{for vessels of } L_{BP} \text{ of 45 metres and over.}$$

7.3 The trim referred to for all vessels with a designed rake of keel is the trim of the baseline.

7.4 In all cases where the trim exceeds the appropriate values listed above, the 'as inclined' waterplane on the lines plan must be used to calculate the displacement, LCB, VCB and BM_0 at inclining. The full calculations, together with a copy of the lines plan and table of offsets, must be submitted with the Inclining Experiment report.

7.5 The displacement calculation must take the water density into account.

7.6 The displacement calculation must take any hog or sag into account:

7.6.1 When the 'as inclined' waterplane is used on the lines plan, it must be the hogged or sagged waterplane.

7.6.2 When the hydrostatic information is used, the correction to the displacement derived from the mean of the for'd and aft drafts is:

$$+ 3/4 \text{ Sag in cms x T.P.1 cm}$$

$$\text{or } - 3/4 \text{ Hog in cms x T.P.1 cm}$$

- 7.7 In all cases where reasonable doubt exists as to which of the two categories of allowable trim applies to a particular vessel, at inclining, written contact is to be made with, and a lines plan of the vessel submitted to, the Authority so that a decision can be given.

8. Calculation of the VCG at inclining

- 8.1 For each pendulum:

$$G_F M_o = \frac{(\text{Heeling Moment})}{(\text{Pendulum Deflection})} \times \frac{\text{Pendulum Length}}{\text{Displacement at Inclining}}$$

$$= \frac{w \times d}{m} \times \frac{p}{\Delta}$$

where:

$G_F M_o$ is the initial 'fluid' metacentric height (i.e. reduced by free surface effects);

$\frac{w \times d}{m}$ is the average value calculated in para. 6.4.4.;

$\frac{P}{\Delta}$ is the displacement at inclining (corrected for density and hog or sag).

Note: 'p' and 'm' must be in the same units.

Then $G_F M_o$ for the vessel at inclining is the mean of the $G_F M_o$ values calculated for the two pendulums.

- 8.2 Corrections for free surface effects (FSC) are to be made:

- 8.2.1 In all cases where tanks contain liquids, but are not pressed up, corrections for free surface effects may be applied.
- 8.2.2 It is emphasised that no free surface effects can be claimed for any liquids other than known amounts in calibrated tanks.
- 8.2.3 The free surface numeral to be used in the calculations is that corresponding to the moment of inertia of the actual liquid surface at inclining and specific gravity of the liquid. In a shaped tank, this will require a calculation for the actual liquid surface.
- 8.2.4 The correction for free surface effects (FSC) to be applied to $G_F M_o$ is:

$$FSC = \frac{\sum \text{Free Surface Numerals for all slack tanks}}{\text{Volume of Displacement at inclining}}$$

- 8.3 GM_o as inclined:

$$GM_o = G_F M_o + FSC$$

where GM_o is the initial metacentric height in the 'solid' condition, i.e. without free surface effects.

- 8.4 VCG above baseline at inclining:

$$VCG = KM_o - GM_o$$

where KM_o is the initial transverse metacentric height above baseline at inclining.

9. Calculation of the LCG at Inclining

- 9.1 When the hydrostatic curves are used to evaluate the hydrostatic elements at inclining, the position of the LCG is determined from the trim of the baseline between perpendiculars, the LCB at level trim, and the MCT1 cm.
- 9.2 When an inclined waterplane is used to calculate the hydrostatic elements at inclining, the position of the LCB is one of the 'as inclined' elements determined. The LCG is vertically above the LCB at inclining.

To calculate the distance of the LCG from midships, a trim correction must be applied to the distance of the LCB from midships to take account of the height of the VCG above the VCB.

10. Calculation of the lightship particulars

- 10.1 The lightship condition is deemed to be that of the vessel complete and ready for sea with all spares and equipment on board, all fluid systems primed, and all permanent solid ballast fixed in position. All fuel oil, lubricating oil, fresh water, water ballast and cargo tanks, and all cargo spaces are to be empty, no passengers, nor crew and effects, and no consumable stores are to be included. If the Owner requires an 'Owner's Lightship' condition different from this, it is to be shown separately, in detail, and clearly labelled 'Owner's Lightship Condition'.
- 10.2 A summary table similar to table 10.2 is to be prepared. In this table the total of the 'items on', the total of the 'solid items off' and the total of the 'liquid items off' are applied to the particulars of the vessel 'as inclined' to obtain the vessel's lightship characteristics.

11. Inclining experiment report

- 11.1 An Inclining Experiment Report is to be prepared which covers the following in full:
- 11.1.1 Date, time and place of the experiment;
- 11.1.2 The wind, weather, tidal and sea conditions;
- 11.1.3 The vessel's heading and mooring conditions;
- 11.1.4 The names and designations of those carrying out the Inclining Experiment and the total number of persons on board;
- 11.1.5 Particulars of the vessel:
- 11.1.5.1 Length between the perpendiculars (L_{BP}) nominated for use throughout the stability data by the Consultant. . . .
- 11.1.5.2 Maximum moulded breadth at midships (L_{BP}). . . . (The maximum breadth to the outside of the shell in vessels having other than a metal shell).
- 11.1.5.3 Moulded depth at midships (L_{BP}) (from top of keel to underside of the deck stringer plate at side for steel vessels). . . . (To be measured from the rabbet line in timber or composite vessels).
- 11.1.5.4 Thickness of the keel plate or depth of keel at midships (L_{BP}). . . . (where appropriate).
- 11.1.5.5 Thickness of the deck stringer plate at side at midships (L_{BP}). . . .
- 11.1.5.6 If appropriate, the designed rake of keel used by the Consultant in his calculations. Details are to be shown on a sketch.
- 11.1.5.7 Longitudinal position of the forward draft marks relative to the forward perpendicular. Sketch or table is to be provided for clarity.
- 11.1.5.8 Longitudinal position of aft draft marks relative to the aft perpendicular. . . .
- 11.1.5.9 Longitudinal position of midships (L_{BP}) relative to the nearest frame. . . .
- 11.1.5.10 Frame spacing. Where frame spacing is not uniform throughout the vessel's length, show details on a dimensioned sketch;
- 11.1.6 Every reading and measurement taken during the Inclining Experiment;
- 11.1.7 The complete calculations based on the readings and measurements referred to in 11.1.6 for the derivation of the lightship displacement, vertical centre of gravity and longitudinal centre of gravity. In all places throughout the calculations where sketches are appropriate, they are to be provided. The calculations are to include a statement of the maximum angle of inclination achieved during the heeling of the vessel, and a statement of the percentage of the lightship displacement represented by the liquids on board at inclining; and
- 11.1.8 The inclusion of an up-to-date general arrangement plan, the hydrostatic information, a lines plan, and tank calibration and free surface information.
- 11.2 The accuracy of the Inclining Experiment and the calculations should be based on the following concepts:
- 11.2.1 As the lightship particulars calculated from the Inclining Experiment are the basis of every loading condition in the trim and stability booklet, every care is to be taken in conducting the experiment, calculating the results and finally checking them to ensure their accuracy.

- 11.2.2 The object of the Inclining Experiment is to determine the lightship displacement, VCG and LCG of the vessel with the highest degree of accuracy obtainable with the equipment available, used with skill and care. Limitations on the overall accuracy achieved are imposed by such factors as:
- 11.2.2.1 The accuracy of hydrostatic calculations based on Simpson's or other rules for integration.
 - 11.2.2.2 The accuracy of the verification of the inclining masses, and of the measuring of the distances moved by their centres of gravity at each mass movement.
 - 11.2.2.3 The accuracy of the reading of the draughts. This is governed by the accuracy with which the draught marks have been 'cut in', and by the water conditions when the readings are being taken.
 - 11.2.2.4 The accuracy of the measurement of the pendulum effective lengths and measurement of the pendulum movements.
- The calculations are to be carried out to a degree of accuracy consistent with these limitations.
- 11.3 Diagrams included in the Inclining Experiment Report are to be complete in themselves for their intended purpose, and are not to require reference to another page for interpretation.

12 The Lightship Measurement

- 12.1 When a dispensation from carrying out an Inclining Experiment is given, it is granted on the basis that the subject vessel is similar in all respects to the sister vessel which has stability data approved by the Authority. To confirm that the two vessels are similar in all respects, a Lightship Measurement is to be carried out on the subject vessel.
- The Lightship Measurement is the means of obtaining the lightship displacement and longitudinal centre of gravity of the vessel. The assumption is made that, if the lightship displacements and longitudinal centres of gravity are closely similar, then the vertical centres of gravity of the two vessels should also be closely similar.
- 12.2 The procedures used and the care and accuracy required are the same as those for the Inclining Experiment. The following, however, are not required with a Lightship Measurement:
- 12.2.1 The placing on board of inclining masses;
 - 12.2.2 The movement of the inclining masses across the deck to heel the vessel; and
 - 12.2.3 The measurement of the resulting heel of the vessel by reading the corresponding movements of the pendulums.
- Everything else listed for the carrying out of the Inclining Experiments must be carried out during the Lightship Measurement, and under the same favourable conditions, and in the presence of Surveyor.
- It is emphasised that:
- 12.2.4 The draught marks must have been verified by a Surveyor; and
 - 12.2.5 All readings and measurements taken must be recorded.
- 12.3 Lightship Measurement Report:
- A Lightship Measurement Report is to be prepared which covers, in full, item 11 with the exception of the requirements for the calculation of the lightship vertical centre of gravity.
- 12.4 When the vessel's lightship displacement and longitudinal centre of gravity have been determined, a table is to be prepared comparing these values with those of the sister vessel.
- If the results are closely similar, the subject vessel will be adjudged to be a sister to the vessel with approved stability data.
- If the results are not closely similar, then the subject vessel will have to be inclined.
- 12.5 If the lightship comparison is satisfactory, then the lightship characteristics of the vessel with approved stability data are used as the lightship characteristics of the subject vessel.
- 12.6 The approved Inclining Experiment Report of the sister vessel becomes an integral part of the stability data of the subject vessel, and a copy of it is to be included in the stability data of the subject vessel.

Table 6.4.6
Table of mass movements and pendulum readings

<i>Time of reading</i>	<i>Mass movement no.</i>	<i>Direction of mass movement</i>	<i>Mass moved (w)</i>	<i>Distance mass moved (d)</i>	<i>Resulting heeling moment (w x d)</i>	<i>Pendulum deflection (m)</i>	$\frac{w \times d}{m}$	<i>Percentage difference from average</i> $\frac{w \times d \times 100}{m}$
	Initial condition							
	1							
	2							
	3							
	4							
	5							
	6							
						Total average		

APPENDIX B**SPECIFICATION FOR POSITIONING AND MARKING OF DRAUGHT MARKS****1. Introduction**

This specification sets out the requirements for the positioning and marking of draught marks on all vessels, which require approval of their stability data. These draught marks are to be verified by a Surveyor.

2. Forward Draught Marks

2.1 Are to follow the line of the stem.

2.2 In the following cases are to be measured from the line of the underside of the keel. These cases which are for vessels having the underside of their keels parallel to the designed waterline are illustrated by the following diagrams:

2.2.1 Vessels with a raked stem and cut-up forward—fig. 1;

2.2.2 Vessels with a bulbous bow—fig. 2; and

2.2.3 Landing craft—fig. 3.

2.3 In vessels with a designed rake of keel the draught marks are to be measured from the line parallel to the designed waterline passing through the tangent point forward. This is illustrated on fig. 4.

3. Aft Draught Marks

3.1 Are to be placed on the stern post or, in a vessel without a stern post, in the line of the centre of the rudder stock.

3.2 In vessels with a stern post the draught marks are to be measured from the underside of the keel.

3.3 In vessels without a stern post the draught marks are to be measured from a line which is parallel to the designed waterline and passes through the lowest point of the skeg or sole piece.

3.4 While draught marks must be in the line of the centre of the rudder stock they must not, in any circumstance, be placed on the rudder or movable Kort Nozzles.

3.5 In order to be able to read the complete draught range, a second set of draught marks are required forward of the rudder stock:

3.5.1 This set is to be placed in the aftermost line which still allows the draught marks to be on the skeg itself.

3.6 In vessels with a rake of keel, the draught marks are to be placed in a line perpendicular to the designed waterline, NOT perpendicular to the line of the underside of the keel.

3.7 The various draught mark positions referred to above are illustrated in the following diagrams:

3.7.1 Vessels having the underside of their keels parallel to the designed waterline:

3.7.1.1 Vessels with a stern post—fig. 5.

3.7.1.2 Vessels without a stem post—fig. 6.

3.7.1.3 Vessels with a skeg aft—fig. 7.

3.7.1.4 Landing craft—fig. 8.

3.7.2 Vessels with a designed rake of keel:

3.7.2.1 Vessels with a stern post—fig. 9.

3.7.2.2 Vessels without a stern post—fig. 10.

3.7.2.3 Vessels with a skeg aft—fig. 4.

4. All Draught Marks

4.1 Are to be marked at 2 decimetre intervals with Arabic numerals 1 decimetre in height.

4.2 Are to have each metre marked with the letter 'M'.

4.3 Are to have the appropriate metre mark included in the uppermost draught mark. This is illustrated in fig. 11.

5. Draught Mark Longitudinal Positions

- 5.1 To carry out trim and stability calculations it is essential to know the longitudinal positions of the draught marks relative to the forward and aft perpendiculars.
- 5.2 For this reason every draught mark must be related to a longitudinal datum(s) which can be accurately determined at the draught mark verification survey. Such datum(s) could be the rudder stock centre line or a frame convenient to the draught marks.
- 5.3 The datum(s) used must be recorded and the longitudinal distance of each draught mark therefrom must also be recorded.
- 5.4 Copies of this information are to be forwarded to the Authority.

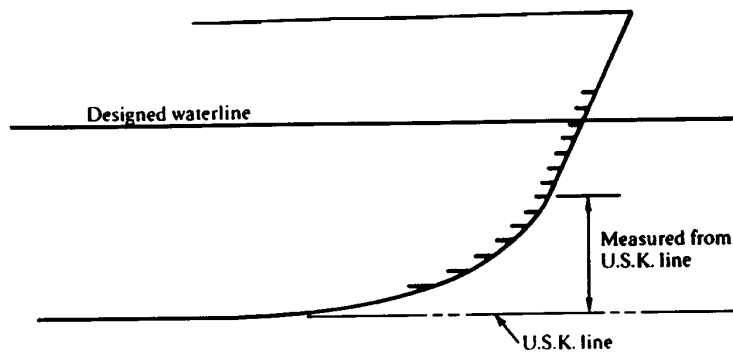

Figure 1 VESSEL WITH A RAKED STEM AND CUT-UP FORWARD

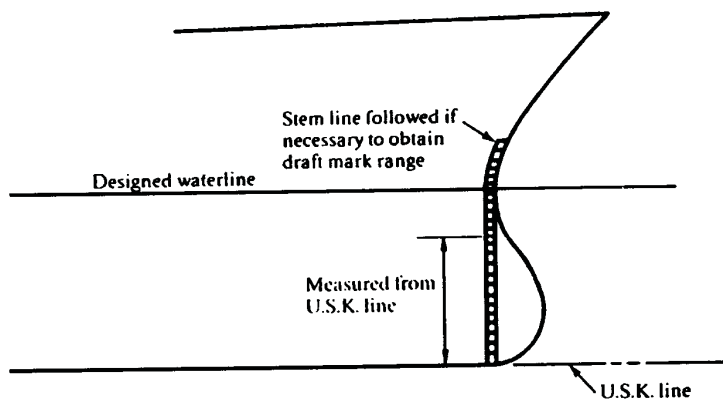
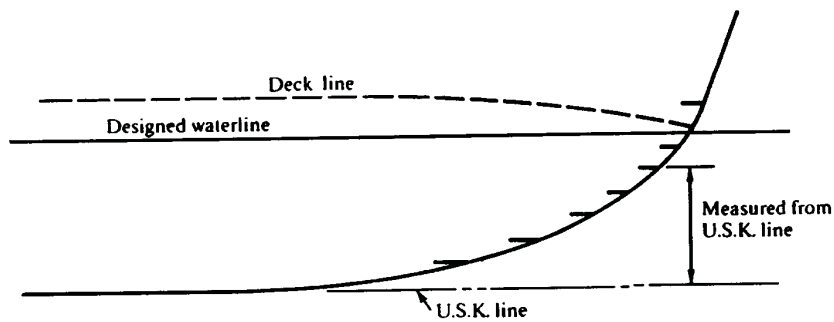

Figure 2 VESSEL WITH A BULBOUS BOW



**Figure 3 VESSEL WITH A ROUNDED STEM
(LANDING CRAFT AND BARGE TYPES)**

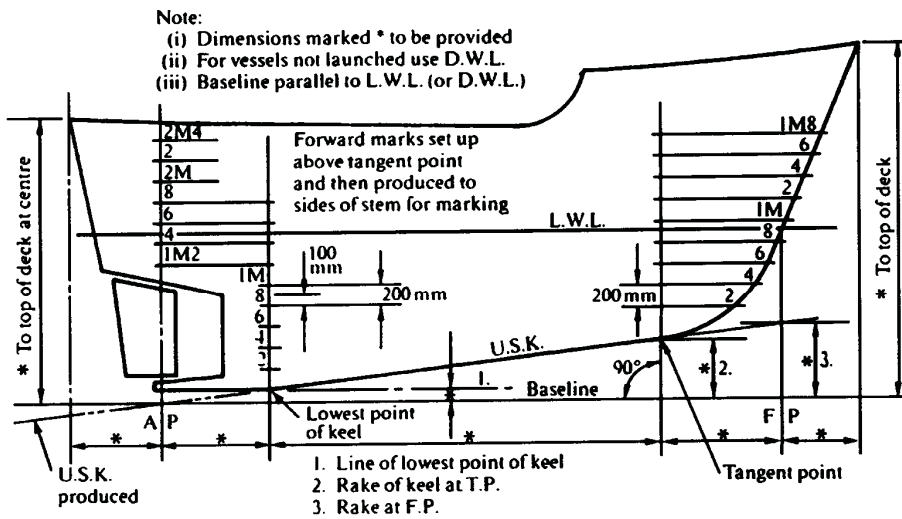

Figure 4

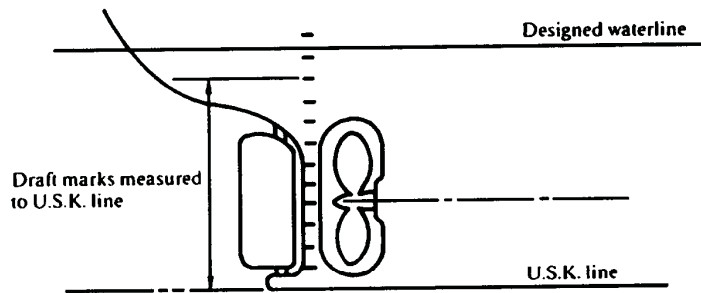

Figure 5 VESSEL WITH A STERN POST

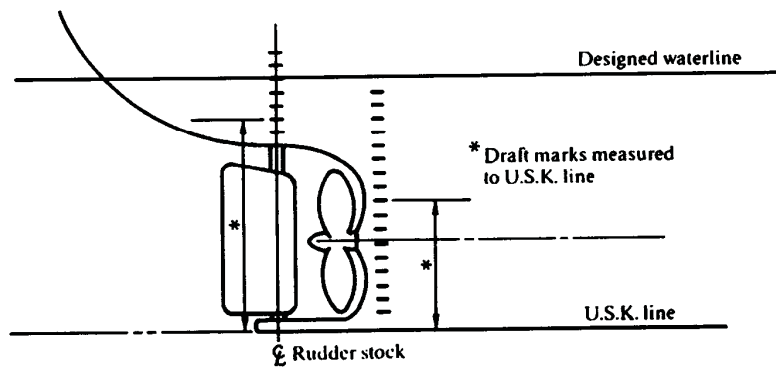

Figure 6 VESSEL WITHOUT A STERN POST

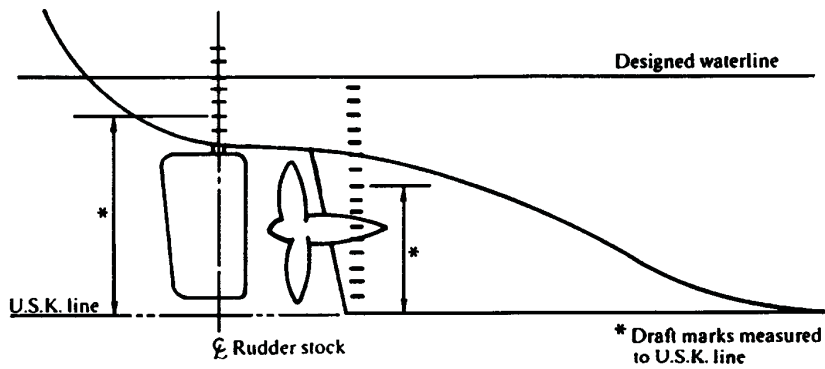

Figure 7 VESSEL WITH A SKEG AFT

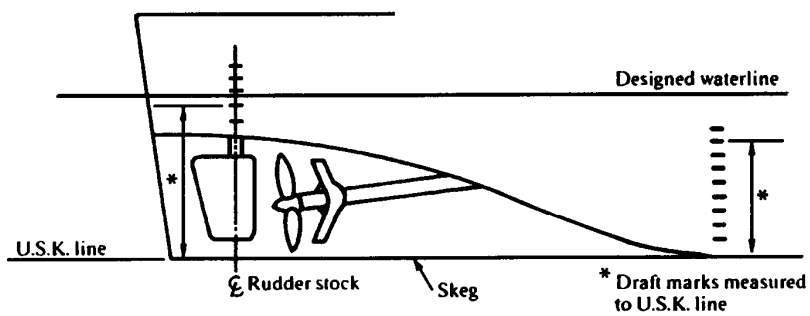

Figure 8 LANDING BARGE

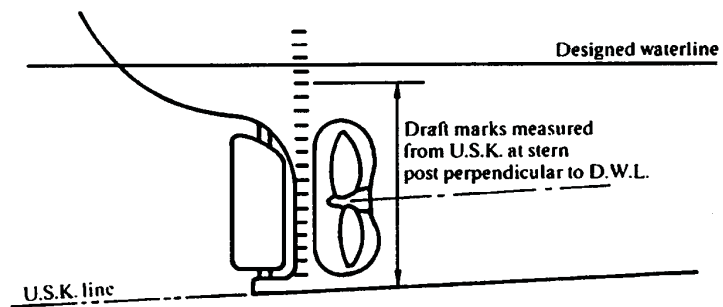

Figure 9 RAKED KEEL — VESSEL WITH A STERN POST

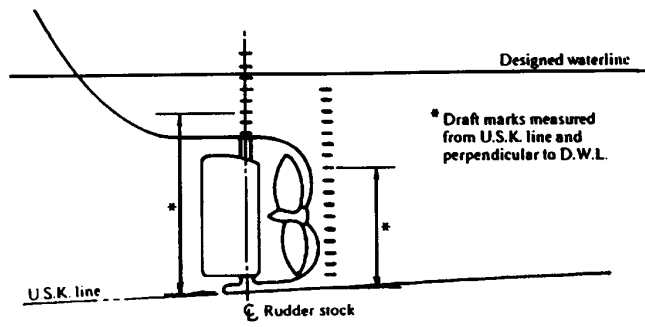

Figure 10 RAKED KEEL — VESSEL WITHOUT A STERN POST

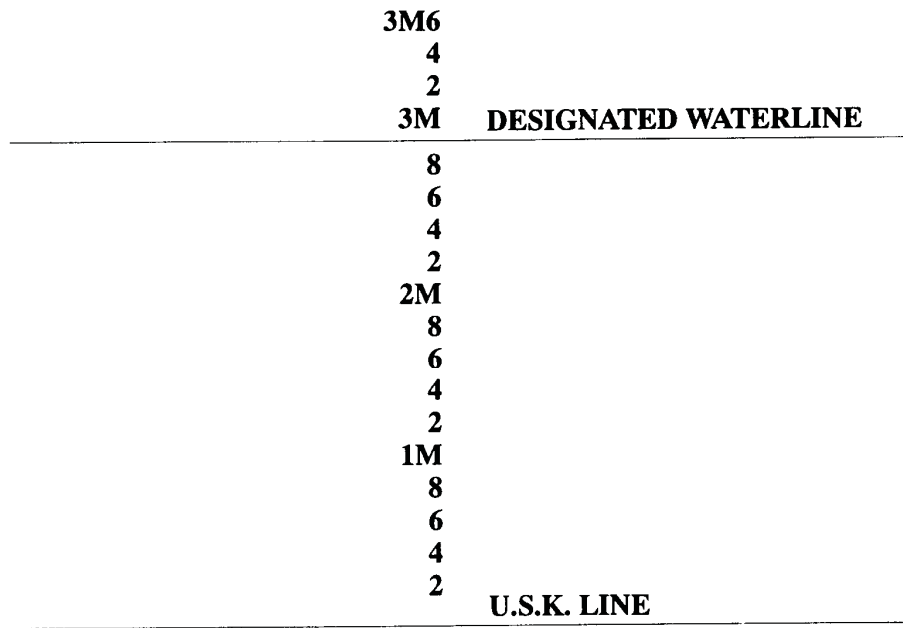

Fig. 11 METRIC DRAFT MARKS